

**Part No. 060242-10, Rev. A**  
**December 2008**

# **OmniSwitch 9000E Series Hardware Users Guide**

Alcatel-Lucent 

**[www.alcatel-lucent.com](http://www.alcatel-lucent.com)**

---

**This user guide documents OmniSwitch 9000E Series hardware, including chassis and associated components. The specifications described in this guide are subject to change without notice.**

Copyright © 2007 by Alcatel-Lucent. All rights reserved. This document may not be reproduced in whole or in part without the express written permission of Alcatel-Lucent.

Alcatel-Lucent<sup>®</sup> and the Alcatel-Lucent logo are registered trademarks of Alcatel-Lucent. Xylan<sup>®</sup>, OmniSwitch<sup>®</sup>, OmniStack<sup>®</sup>, and Alcatel-Lucent OmniVista<sup>®</sup> are registered trademarks of Alcatel-Lucent.

OmniAccess<sup>™</sup>, Omni Switch/Router<sup>™</sup>, PolicyView<sup>™</sup>, RouterView<sup>™</sup>, SwitchManager<sup>™</sup>, VoiceView<sup>™</sup>, WebView<sup>™</sup>, X-Cell<sup>™</sup>, X-Vision<sup>™</sup>, and the Xylan logo are trademarks of Alcatel-Lucent.

This OmniSwitch product contains components which may be covered by one or more of the following U.S. Patents:

- U.S. Patent No. 6,339,830
- U.S. Patent No. 6,070,243
- U.S. Patent No. 6,061,368
- U.S. Patent No. 5,394,402
- U.S. Patent No. 6,047,024
- U.S. Patent No. 6,314,106
- U.S. Patent No. 6,542,507
- U.S. Patent No. 6,874,090



**26801 West Agoura Road  
Calabasas, CA 91301  
(818) 880-3500 FAX (818) 880-3505  
support@ind.alcatel.com**

**US Customer Support—(800) 995-2696  
International Customer Support—(818) 878-4507  
Internet—service.esd.alcatel-lucent.com**

# Contents

	<b>About This Guide</b> .....	vii
	Supported Platforms .....	vii
	Who Should Read this Manual? .....	vii
	When Should I Read this Manual? .....	viii
	What is in this Manual? .....	viii
	What is Not in this Manual? .....	viii
	How is the Information Organized? .....	ix
	Documentation Roadmap .....	ix
	Related Documentation .....	xi
	Included / Downloading Product Documentation .....	xii
	Technical Support .....	xii
<b>Chapter 1</b>	<b>OmniSwitch 9000E Series</b> .....	1-1
	Availability Features .....	1-2
	Hardware Redundancy .....	1-2
	Smart Continuous Switching .....	1-3
	Software Rollback .....	1-3
	Hot Swapping .....	1-4
	Hardware Monitoring .....	1-4
	Power Checking Sequence .....	1-5
<b>Chapter 2</b>	<b>Chassis and Power Supplies</b> .....	2-1
	OmniSwitch 9800E .....	2-2
	OmniSwitch 9700E .....	2-5
	Chassis Slot Numbering .....	2-8
	Viewing Chassis Slot Information .....	2-9
	Mounting the Switch .....	2-9
	Power Supplies .....	2-13
	600 Watt DC-to-DC Power Supply .....	2-15
	DC Power Supply Connection .....	2-16
	Connecting the DC Cable Harness to the Chassis Power Supply .....	2-16
	Connecting the DC Cable Harness to the DC Power Source .....	2-16
	Chassis Power Supply Module Support .....	2-17
	Monitoring Chassis Power .....	2-18
	Checking Chassis Power Before Adding a Module .....	2-18
	Example 1: Adequate Power to Add a Module .....	2-19

Example 2: Inadequate Power to Add a Module .....	2-20
Checking Chassis Power Before Shutting Off or Removing a Power Supply .....	2-22
Example 1: Adequate Power to Remove a Power Supply .....	2-22
Example 2: Inadequate Power to Remove a Power Supply .....	2-23
Adding a Power Supply .....	2-23
Hot Swapping a Power Supply .....	2-23
Permanently Removing a Power Supply .....	2-23
Power Supply Redundancy .....	2-24
Redundancy Defined .....	2-24
Installing a Power Supply .....	2-25
Removing a Power Supply .....	2-27
Power Cords .....	2-28
Redundant AC Circuit Recommendation .....	2-29
Grounding the Chassis .....	2-30
Temperature Management .....	2-30
Temperature Errors .....	2-31
Chassis Fan Tray .....	2-32
Monitoring Fan Tray Status .....	2-33
Fan Redundancy .....	2-33
Hot Swapping the Fan Tray .....	2-33
Removing the Fan Tray .....	2-34
Installing the New Fan Tray .....	2-35
Chassis Airflow .....	2-36
Power Supply Fans .....	2-38
Blank Cover Panels and Chassis Airflow .....	2-39
<b>Chapter 3</b>	
<b>Chassis Management Module (CMM) .....</b>	<b>3-1</b>
CMM Slot Locations .....	3-2
OS9700E-CMM Versus OS9800E-CMM .....	3-2
CMM Front Panel .....	3-3
Ethernet Management Port (EMP) .....	3-5
Routed Access to the EMP .....	3-6
EMP Cable Requirements .....	3-6
Console Port .....	3-7
Serial Connection to the Console Port .....	3-7
Configuring X-ON/X-OFF Protocol .....	3-9
CMM Redundancy .....	3-10
CMM Failover Sequence .....	3-10
Synchronizing the Primary and Secondary CMMs .....	3-11
CMM Switching Fabric .....	3-11
Hot Swapping CMM Modules .....	3-12
Module Presence Signalling .....	3-12
Hot Swap Requirements .....	3-12
Managing CMM Modules .....	3-14
Reloading a CMM Module .....	3-14
Switching the Primary and Secondary Roles .....	3-14

Monitoring CMM Modules .....	3-15
Front Panel LEDs .....	3-15
Accessing General CMM Information .....	3-15
CMM Hardware Information .....	3-15
Operating Status of CMM-Related Components .....	3-16
CLI Commands Supported on Both the Primary and Secondary CMMs .....	3-16
Chassis-Based MAC Address .....	3-18
Pinouts .....	3-18
<b>Chapter 4 Network Interface (NI) Modules .....</b>	<b>4-1</b>
In This Chapter .....	4-1
GNI Modules .....	4-3
OS9-GNI-C24E Front Panel .....	4-4
OS9-GNI-U24E Front Panel .....	4-6
.....	4-7
XNI Modules .....	4-8
OS9-XNI-U2E Front Panel .....	4-9
Smart Continuous Switching .....	4-11
Module Priorities During Boot Sequence .....	4-11
Managing NI Modules .....	4-11
Turning Power On or Off for a Specific NI Module .....	4-11
Individual NI Reload .....	4-11
Monitoring NI Modules .....	4-12
Front Panel LEDs .....	4-12
Accessing General NI Information .....	4-12
Hot Swapping NI Modules .....	4-13
Removing and Adding Modules .....	4-14
Using the Grounding Wrist Strap and Chassis Grounding Lug .....	4-14
Module Types and Slot Positions .....	4-15
Removing a Module .....	4-15
Adding a Module .....	4-17
Pinouts .....	4-19
10/100 Mbps Ethernet Port – RJ-45 Pinout .....	4-19
1 Gigabit Ethernet Port – RJ-45 Pinout .....	4-19
Handling Fiber and Fiber Optic Connectors .....	4-20
<b>Appendix A Regulatory Compliance and Safety Information .....</b>	<b>A-1</b>
Declaration of Conformity: CE Mark .....	A-1
Waste Electrical and Electronic Equipment (WEEE) Statement .....	A-1
China RoHS: Hazardous Substance Table .....	A-2
Standards Compliance .....	A-4
FCC Class A, Part 15 .....	A-5
Canada Class A Statement .....	A-5
JATE .....	A-5

---

CISPR22 Class A warning .....	A-6
VCCI .....	A-6
Class A Warning for Taiwan and Other Chinese Markets .....	A-6
Translated Safety Warnings .....	A-7
Chassis Lifting Warning .....	A-7
Blank Panels Warning .....	A-7
Electrical Storm Warning .....	A-7
Installation Warning .....	A-8
Invisible Laser Radiation Warning .....	A-8
Lithium Battery Warning .....	A-9
Operating Voltage Warning .....	A-9
Power Disconnection Warning .....	A-10
Proper Earthing Requirement Warning .....	A-10
Read Important Safety Information Warning .....	A-11
Restricted Access Location Warning .....	A-11
Wrist Strap Warning .....	A-12
Instrucciones de seguridad en español .....	A-13
Advertencia sobre el levantamiento del chasis .....	A-13
Advertencia de las tapaderas en blanco .....	A-13
Advertencia en caso de tormenta eléctrica .....	A-13
Advertencia de instalación .....	A-13
Advertencia de radiación láser invisible .....	A-13
Advertencia de la batería de litio .....	A-13
Advertencia sobre la tensión de operación .....	A-13
Advertencia sobre la desconexión de la fuente .....	A-13
Advertencia sobre una apropiada conexión a tierra .....	A-14
Leer “información importante de seguridad” .....	A-14
Advertencia de acceso restringido .....	A-14
Advertencia de pulsera antiestática .....	A-14
Clase de seguridad .....	A-14
Advertencia de fuentes de poder .....	A-14
<b>Index</b> .....	Index-1

# About This Guide

This *OmniSwitch 9000E Series Hardware Users Guide* describes your switch hardware components and basic switch hardware procedures.

## Supported Platforms

This information in this guide applies to the following products:

- OmniSwitch 9700E
- OmniSwitch 9800E

The OmniSwitch 9800E includes 18 slots for high performance 10/100/1000 Ethernet, Gigabit Ethernet, and 10 Gigabit Network Interface (NI) modules. The OmniSwitch 9700E includes 10 slots for high performance 10/100/1000 Ethernet, Gigabit Ethernet, and 10 Gigabit Network Interface (NI) modules.

## Unsupported Platforms

The information in this guide does not apply to the following products:

- OmniSwitch (original version with no numeric model name)
- OmniSwitch 6600 Family
- OmniSwitch 6800 Series
- OmniSwitch 7700/7800
- OmniSwitch 8800
- OmniSwitch 9000
- Omni Switch/Router
- OmniStack
- OmniAccess

## Who Should Read this Manual?

The audience for this users guide is network administrators and IT support personnel who need to configure, maintain, and monitor switches and routers in a live network. However, anyone wishing to gain knowledge on the OmniSwitch 9000E Series hardware will benefit from the material in this guide.

## When Should I Read this Manual?

Read this guide as soon as you are ready to familiarize yourself with your switch hardware components. You should have already stepped through the first login procedures and read the brief hardware overviews in the *OmniSwitch 9000E Series Getting Started Guide*.

You should already be familiar with the very basics of the switch hardware, such as module LEDs and module installation procedures. This manual will help you understand your switch hardware components (chassis, cooling fans, power supplies, Network Interface modules, Chassis Management Modules) in greater depth.

## What is in this Manual?

This users guide includes the following hardware-related information:

- Descriptions of “Availability” features.
- Technical specifications for chassis, power supplies, Network Interface (NI) modules, and Chassis Management Modules (CMMs).
- Power supply requirements.
- The dynamics of chassis airflow, including detailed illustrations of proper and improper airflow configurations.
- Hot swapping power supplies, fan trays, Network Interface (NI) modules, and Chassis Management Modules (CMMs).
- Installation and removal procedures for power supplies, fan trays, Network Interface (NI) modules, and Chassis Management Modules (CMMs).
- Detailed illustrations and LED descriptions for power supplies, Network Interface (NI) modules, and Chassis Management Modules (CMMs).
- CMM redundancy.
- Hardware-related Command Line Interface (CLI) commands.

## What is Not in this Manual?

The descriptive and procedural information in this manual focuses on switch hardware. It includes information on some CLI commands that pertain directly to hardware configuration, but it is not intended as a software users guide. There are several OmniSwitch 9000E Series users guides that focus on switch software configuration. Consult those guides for detailed information and examples for configuring your switch software to operate in a live network environment. See [“Documentation Roadmap” on page -ix](#) and [“Related Documentation” on page -xi](#) for further information on software configuration guides available for your switch.



# How is the Information Organized?

Each chapter in this guide focuses on a specific hardware component, such as the Chassis Management Module (CMM), or a set of hardware components. All descriptive, technical specification, and procedural information for a hardware component can be found in the chapter dedicated to that component.

## Documentation Roadmap

The OmniSwitch 9000E Series user documentation suite was designed to supply you with information at several critical junctures of the configuration process. The following section outlines a roadmap of the manuals that will help you at each stage of the configuration process. Under each stage, we point you to the manual or manuals that will be most helpful to you.

### Stage 1: Using the Switch for the First Time

**Pertinent Documentation:** *OmniSwitch 9000E Series Getting Started Guide*  
*Release Notes*

A hard-copy *OmniSwitch 9000E Series Getting Started Guide* is included with your switch; this guide provides all the information you need to get your switch up and running the first time. It provides information on unpacking the switch, rack mounting the switch, installing NI modules, unlocking access control, setting the switch's IP address, and setting up a password. It also includes succinct overview information on fundamental aspects of the switch, such as hardware LEDs, the software directory structure, CLI conventions, and web-based management.

At this time you should also familiarize yourself with the Release Notes that accompanied your switch. This document includes important information on feature limitations that are not included in other user guides.

### Stage 2: Gaining Familiarity with Basic Switch Functions

**Pertinent Documentation:** *OmniSwitch 9000E Series Hardware Users Guide*  
*OmniSwitch AOS Release 6 Switch Management Guide*

Once you have your switch up and running, you will want to begin investigating basic aspects of its hardware and software. Information about switch hardware is provided in the *OmniSwitch 9000E Series Hardware Guide*. This guide provides specifications, illustrations, and descriptions of all hardware components, such as chassis, power supplies, Chassis Management Modules (CMMs), Network Interface (NI) modules, and cooling fans. It also includes steps for common procedures, such as removing and installing switch components.

The *OmniSwitch AOS Release 6 Switch Management Guide* is the primary users guide for the basic software features on a single switch. This guide contains information on the switch directory structure, basic file and directory utilities, switch access security, SNMP, and web-based management. It is recommended that you read this guide before connecting your switch to the network.

## Stage 3: Integrating the Switch Into a Network

**Pertinent Documentation:** *OmniSwitch AOS Release 6 Network Configuration Guide*  
*OmniSwitch AOS Release 6 Advanced Routing Configuration Guide*

When you are ready to connect your switch to the network, you will need to learn how the OmniSwitch implements fundamental software features, such as 802.1Q, VLANs, Spanning Tree, and network routing protocols. The *OmniSwitch AOS Release 6 Network Configuration Guide* contains overview information, procedures, and examples on how standard networking technologies are configured in the OmniSwitch 9000E Series.

The *OmniSwitch AOs Release 6 Advanced Routing Configuration Guide* includes configuration information for networks using advanced routing technologies (OSPF and BGP) and multicast routing protocols (DVMRP and PIM-SM).

### Anytime

The *OmniSwitch CLI Reference Guide* contains comprehensive information on all CLI commands supported by the switch. This guide includes syntax, default, usage, example, related CLI command, and CLI-to-MIB variable mapping information for all CLI commands supported by the switch. This guide can be consulted anytime during the configuration process to find detailed and specific information on each CLI command.

## Related Documentation

The following are the titles and descriptions of all the OmniSwitch 9000E Series user manuals:

- *OmniSwitch 9000E Series Getting Started Guide*

Describes the hardware and software procedures for getting an OmniSwitch 9000E Series up and running. Also provides information on fundamental aspects of OmniSwitch software architecture.
- *OmniSwitch 9000E Series Hardware Users Guide*

Complete technical specifications and procedures for all OmniSwitch 9000E Series chassis, power supplies, fans, and Network Interface (NI) modules.
- *OmniSwitch CLI Reference Guide*

Complete reference to all CLI commands supported on the OmniSwitch. Includes syntax definitions, default values, examples, usage guidelines and CLI-to-MIB variable mappings.
- *OmniSwitch AOS Release 6 Switch Management Guide*

Includes procedures for readying an individual switch for integration into a network. Topics include the software directory architecture, image rollback protections, authenticated switch access, managing switch files, system configuration, using SNMP, and using web management software (WebView).
- *OmniSwitch AOS Release 6 Network Configuration Guide*

Includes network configuration procedures and descriptive information on all the major software features and protocols included in the base software package. Chapters cover Layer 2 information (Ethernet and VLAN configuration), Layer 3 information (routing protocols, such as RIP and IPX), security options (authenticated VLANs), Quality of Service (QoS), link aggregation, and server load balancing.
- *OmniSwitch AOS Release 6 Advanced Routing Configuration Guide*

Includes network configuration procedures and descriptive information on all the software features and protocols included in the advanced routing software package. Chapters cover multicast routing (DVMRP and PIM-SM), Open Shortest Path First (OSPF), and Border Gateway Protocol (BGP).
- *OmniSwitch Transceivers Guide*

Includes SFP and XFP transceiver specifications and product compatibility information.
- *Technical Tips, Field Notices*

Includes information published by Alcatel-Lucent's Customer Support group.
- *Release Notes*

Includes critical Open Problem Reports, feature exceptions, and other important information on the features supported in the current release and any limitations to their support.

# Included / Downloading Product Documentation

Some products are shipped with documentation included on a User Manual CD that accompanies the switch. This CD also includes documentation for other Alcatel-Lucent data enterprise products.

All products are shipped with a Product Documentation Card that provides details for downloading documentation for all OmniSwitch and other Alcatel-Lucent data enterprise products.

All documentation is in PDF format and requires the Adobe Acrobat Reader program for viewing. Acrobat Reader freeware is available at [www.adobe.com](http://www.adobe.com).

---

**Note.** In order to take advantage of the documentation CD's global search feature, it is recommended that you select the option for *searching PDF files* before downloading Acrobat Reader freeware.

---

To verify that you are using Acrobat Reader with the global search option, look for the following button in the toolbar:



---

**Note.** When printing pages from the documentation PDFs, de-select Fit to Page if it is selected in your print dialog. Otherwise pages may print with slightly smaller margins.

---

## Technical Support

An Alcatel-Lucent service agreement brings your company the assurance of 7x24 no-excuses technical support. You'll also receive regular software updates to maintain and maximize your Alcatel-Lucent product's features and functionality and on-site hardware replacement through our global network of highly qualified service delivery partners. Additionally, with 24-hour-a-day access to Alcatel-Lucent's Service and Support web page, you'll be able to view and update any case (open or closed) that you have reported to Alcatel-Lucent's technical support, open a new case or access helpful release notes, technical bulletins, and manuals. For more information on Alcatel-Lucent's Service Programs, see our web page at [service.esd.alcatel-lucent.com](http://service.esd.alcatel-lucent.com), call us at 1-800-995-2696, or email us at [support@ind.alcatel.com](mailto:support@ind.alcatel.com).

# 1 OmniSwitch 9000E Series

The OmniSwitch 9000E introduces a new set of modules for the OmniSwitch 9700 & 9800 chassis. These new modules have been designed using the latest generation of hardware to address the specific needs for Datacenter & Campus networks. In this release, these switches come in two chassis configurations listed below.

Refer to the sections below for additional details on the OmniSwitch 9000E Series.

## **OmniSwitch 9000E Series**

The 18-slot OS9800E and 10-slot OS9700E offer a new set of modules to address the needs for Data-center & Campus networks.

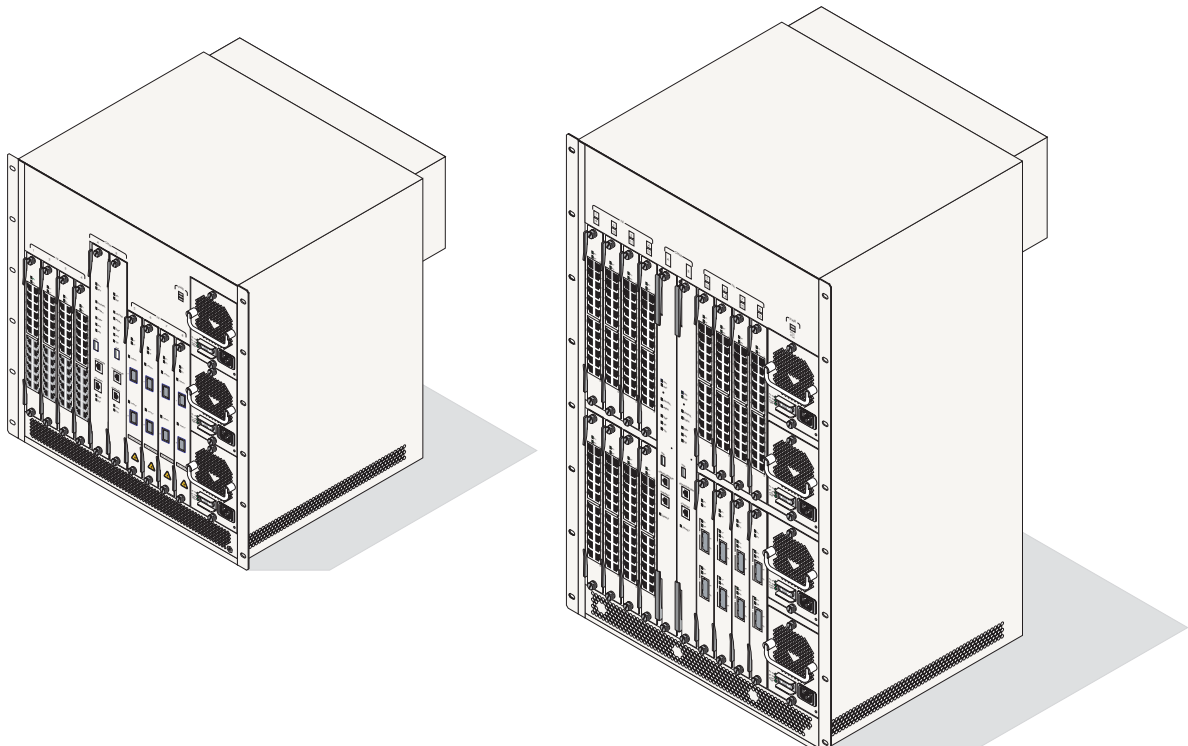

**OmniSwitch OS9700E, OS9800E**

# Availability Features

The switch provides a broad variety of *Availability* features. Availability features are hardware and software-based safeguards that help prevent the loss of data flow in the unlikely event of a subsystem failure. In addition, some Availability features allow you to maintain or replace hardware components without powering off your switch or interrupting switch operations. Combined, these features provide added resiliency and help ensure that your switch is consistently available for your day-to-day network operations.

Hardware-related Availability features include:

- [Hardware Redundancy](#)
- [Smart Continuous Switching](#)
- [Software Rollback](#)
- [Hot Swapping](#)
- [Hardware Monitoring](#)
- [Power Checking Sequence](#)

Information on software-related availability is provided in the *OmniSwitch Switch Management Guide* and the *OmniSwitch Network Configuration Guide*. Refer to the corresponding feature chapter (e.g., VRRP).

## Hardware Redundancy

Hardware redundancy refers to backup hardware components. If primary hardware components fail or go offline for any reason, the redundant hardware automatically assumes the primary hardware functions (this is also referred to as *failover*). The following components offer redundancy:

- Chassis Management Modules (CMMs)
- Power Supplies
- Fan Units
- MAC EEPROM

---

**Note.** Redundancy is a key Availability feature; it is recommended that you install redundant hardware components in your switch whenever possible.

---

For detailed information on CMM redundancy, refer to [Chapter 3, “Chassis Management Module \(CMM\).”](#) For information on power supply and fan redundancy, refer to [Chapter 2, “Chassis and Power Supplies.”](#)

## Smart Continuous Switching

In redundant CMM configurations, the switch provides support for NIs during failover. In other words, if the primary CMM fails or goes offline for any reason, NI modules will continue data transmission and routing functions during the secondary CMM's takeover process. This Availability feature is referred to as *Smart Continuous Switching*.

Incoming Layer 2 packets will continue to be sent to the appropriate egress port during failover. Known routes will also be supported. (Note, however, that the NI cannot learn new routes without CMM support. Any new route information will be ignored.) Spanning Tree will continue handling BPDUs received on the switch ports, as well as port link up and down states. The Spanning Tree topology will not be disrupted.

---

**Note.** Smart Continuous Switching is designed to maintain data flow only during CMM failover and is *not* intended to support long-term data flow. If both the primary and secondary CMM modules go offline or are removed from the chassis, switch operations (including all NI support) will be disabled.

---

For more information on CMM redundancy and the failover process, refer to [Chapter 3, “Chassis Management Module \(CMM\).”](#)

## Software Rollback

Software rollback (also referred to as *image rollback*) essentially allows the switch to return to a prior “last known good” version of software in the event of a system software problem. The CMM controls software rollback through its resilient directory structure design (i.e., **/flash/working** and **/flash/certified**).

For detailed information on the software rollback feature, as well as the switch's **/flash/working** and **/flash/certified** directories, refer to the “Managing CMM Directory Contents” chapter in the *Switch Management Guide*.

## Hot Swapping

Hot swapping refers to the action of adding, removing, or replacing certain hardware components without powering off your switch and disrupting other components in the chassis. This feature greatly facilitates hardware upgrades and maintenance and also allows you to easily replace components in the unlikely event of hardware failure. The following hardware components can be hot swapped:

- Chassis Management Modules (CMMs)
- Gigabit Ethernet Network Interface modules (GNIs)
- 10-gigabit Ethernet Network Interface modules (XNIs)
- Power supplies
- Fan tray

---

**Hot Swapping Non-Redundant Management Modules and Power Supplies.** If there is only one CMM or power supply installed in the chassis and either of these components is removed or replaced, all switch functions will stop until a replacement is installed.

---

---

**Hot Swapping NI Modules.** It is recommended that you hot swap NIs of the same type (e.g., OS9-GNI-C24E) whenever possible. Otherwise, the network configuration may be adversely affected.

---

For information on hot swapping CMMs, refer to [Chapter 3, “Chassis Management Module \(CMM\).”](#)  
For information on hot swapping NI modules, refer to [Chapter 4, “Network Interface \(NI\) Modules.”](#)  
For information on hot swapping power supplies and the fan tray, refer to [Chapter 2, “Chassis and Power Supplies.”](#)

## Hardware Monitoring

### Automatic Monitoring

Automatic monitoring refers to the switch’s built-in sensors that automatically monitor operations. The majority of automatic monitoring is provided by the CMM. If an error is detected (e.g., over-threshold temperature), the CMM immediately sends a trap to the user. The trap is displayed on the console in the form of a text error message. (In the case of an over-threshold temperature condition, the CMM displays an amber TEMP LED in addition to sending a trap.)

### LEDs

LEDs, which provide visual status information, are provided on the CMM, NI, and power supply front panels. LEDs are used to indicate conditions, such as hardware and software status, temperature errors, link integrity, data flow, etc. For detailed LED descriptions, refer to the corresponding hardware component chapter (e.g., “Network Interface (NI) Modules”).

### User-Driven Monitoring

User-driven hardware monitoring refers to CLI commands that are entered by the user in order to access the current status of hardware components. The user enters “show” commands that output information to the console. The Show commands for all the features are described in detail in the *OmniSwitch CLI Reference Guide*.



## Power Checking Sequence

The power checking sequence is another built-in Availability feature. This feature helps regulate power in the switch whenever the switch is booted or an NI module is installed in the chassis.

The sequence is a joint effort between the CMM, the NI modules, and the power supplies. During the boot sequence, the primary CMM automatically compares the power consumption required by installed NIs with the power available from the power supplies. If there is not adequate power to support all NIs, the CMM will power on only the supported number of NIs, starting from the first NI slot position.

---

**Important.** During the power checking sequence, CMMs receive priority and are always powered on. NI modules are then powered on sequentially by slot position. In other words, the NI in slot 1 is powered on, then slot 2, then slot 3, etc. For information on slot positions, refer to [Chapter 2, “Chassis and Power Supplies.”](#)

---

### Installing a New NI into a Running Chassis

When an NI module is installed in the chassis, only a small portion of the circuitry is initially powered up. The CMM immediately reads the incoming module's ID and determines how much power the module will require. If the number of power supplies installed in the chassis can provide sufficient power, the CMM turns on the incoming module. If the number of installed power supplies cannot provide sufficient power, the incoming NI will remain powered off.



# 2 Chassis and Power Supplies

The OmniSwitch 9000E Series switches are available in two chassis configurations—the 18-slot OmniSwitch 9800E (OS9800E) and the 10-slot OmniSwitch 9700E (OS9700E). This chapter includes detailed information on each of these chassis types. The topics include:

- Technical specifications on [page 2-7](#).
- Switch mounting information on [page 2-9](#).
- Power supplies and power supply redundancy on [page 2-13](#).
- Temperature management on [page 2-30](#).
- Chassis fan tray on [page 2-32](#).
- Monitoring the chassis components via the Command Line Interface (CLI) on [page 2-18](#).

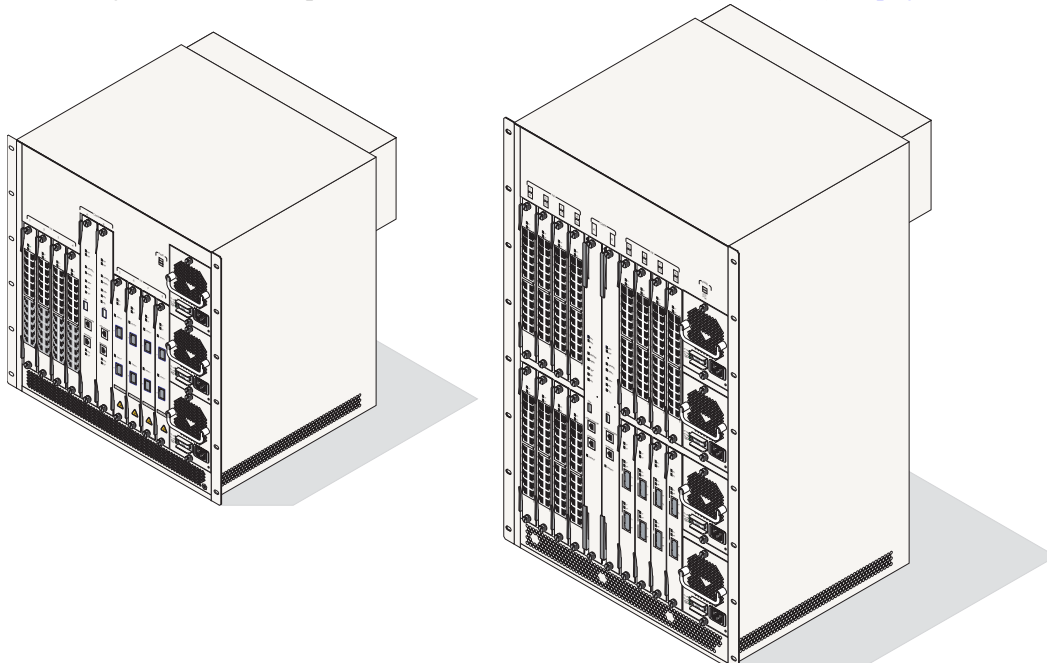

**OmniSwitch OS9700E, OS9800E**

---

**Warning.** OmniSwitch 9700/9800 CMMs and NI modules cannot be mixed with OmniSwitch 9000E Series CMMs or NIs in the same chassis.

---

# OmniSwitch 9800E

The OmniSwitch 9800E is a high performance switch offering 16 slots for Gigabit Ethernet and/or 10-Gigabit Ethernet Network Interface (NI) modules. An additional two slots are reserved for primary and redundant Chassis Management Modules (CMMs). The OmniSwitch 9800E supports a maximum of four power supplies.

**Note.** Power supply requirements are based on the number of NIs installed in the chassis. Refer to [“Power Supplies” on page 2-13](#) for important information on power supplies and power supply redundancy.

The following illustrations outline the major components of the OmniSwitch 9800E switch.

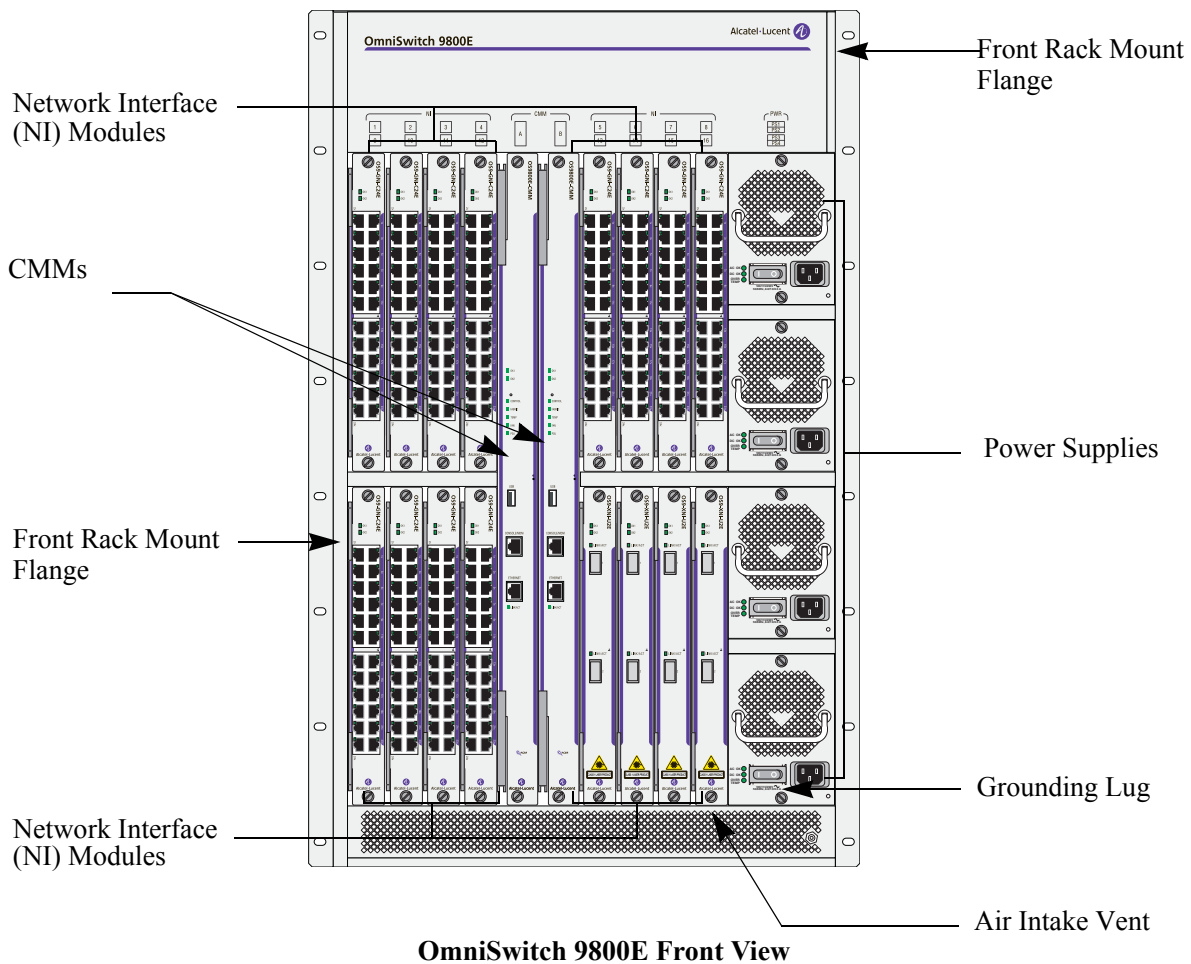

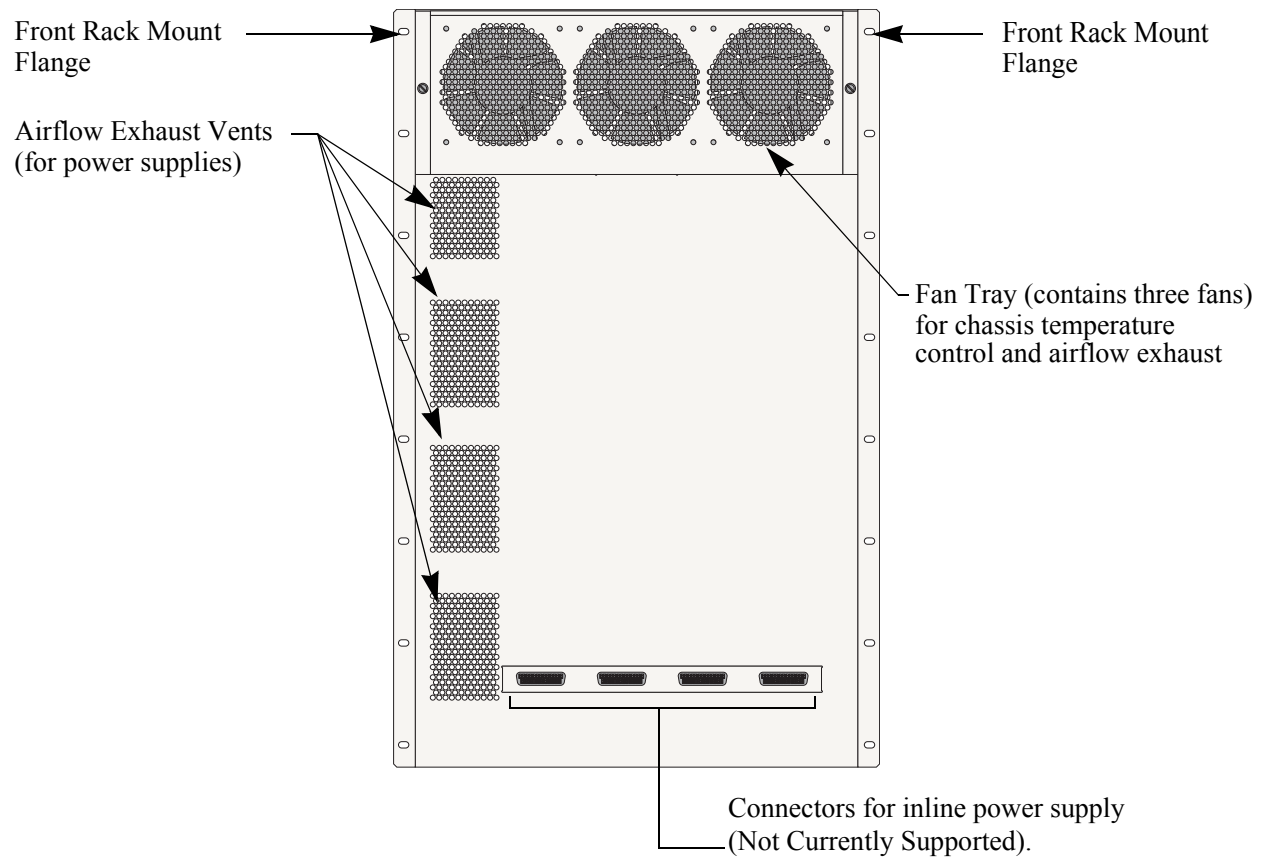
**OmniSwitch 9800E Back View**

**OmniSwitch 9800E Technical Specifications**

Total 10/100/1000 copper Ethernet ports available	384 (Fully-populated with OS9-GNI-C24E modules.)
Total 1000BaseSX Ethernet ports available	384 (Fully-populated with OS9-GNI-U24E modules.)
Total 10-Gigabit Ethernet ports available	32 (Fully-populated with OS9-XNI-U2E modules.)
Total slots available for network interface (NI) modules	16
Total slots available for CMMs	2
Total bays for power supplies	4
Power (Chassis + Fans)	80 Watts (approx.)
Ambient Temperature (Tmra)	Operating: 0°C to 45°C (32°F to 113°F)

**OmniSwitch 9800E Chassis Specifications**

Overall Width (including rack-mount flanges)	19 1/8 inches
Chassis Width (rack-mount flanges not included)	17 9/16 inches
Height	29 3/4 inches
Height (rack units)	17 RU
Overall Depth (including required fan tray)	17 5/16 inches
Chassis Depth (fan tray not included)	14 3/4 inches
Chassis Weight (fully populated)	188 lbs (85 kg)

# OmniSwitch 9700E

The OmniSwitch 9700E is a high performance switch offering eight slots for Gigabit Ethernet and/or 10-gigabit Ethernet Network Interface (NI) modules. Additional two slots are reserved for primary and redundant Chassis Management Modules (CMMs). The OmniSwitch 9700E supports a maximum of three power supplies.

**Note.** Power supply requirements are based on the number of NIs installed in the chassis. Refer to [“Power Supplies” on page 2-13](#) for important information on power supplies and power supply redundancy.

The following illustrations outline the major components of the OmniSwitch 9700E switch.

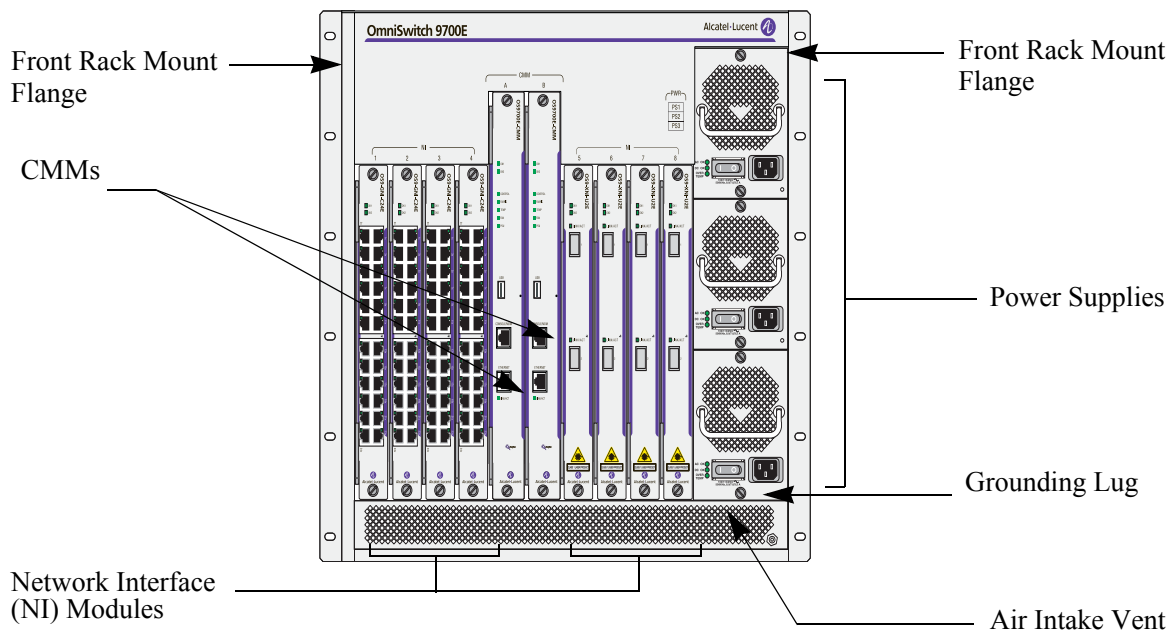

**OmniSwitch 9700E Front View**

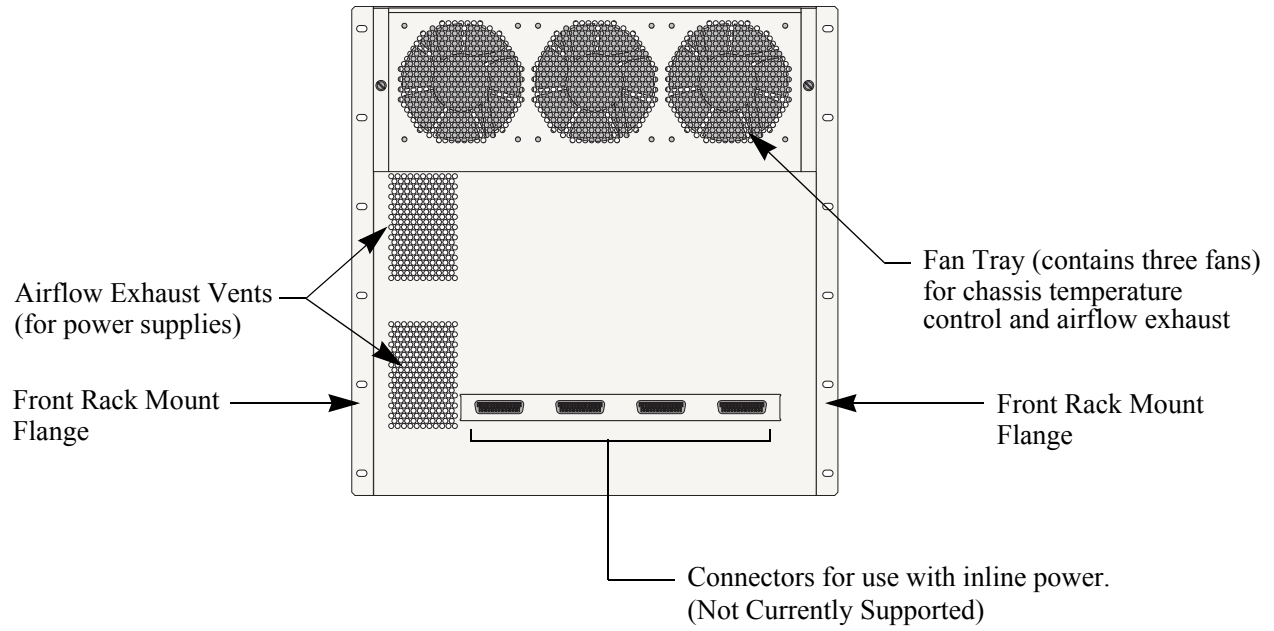

**OmniSwitch 9700E Back View**



---

**OmniSwitch 9700E Technical Specifications**

---

Total 10/100/1000 copper Ethernet ports available	192 (Fully-populated with OS9-GNI-C24E modules.)
Total 1000Base SX fiber Ethernet ports available	192 (Fully-populated with OS9-GNI-U24E modules.)
Total 10-Gigabit Ethernet ports available	16 (Fully-populated with OS9-XNI-U2E modules.)
Total slots for network interface (NI) modules	8
Total slots for CMM	2
Total bays for power supplies	3
Power (Chassis + Fans)	80 Watts (approx.)
Ambient Temperature (Tmra)	Operating: 0°C to 45°C (32°F to 113°F)

---

**OmniSwitch 9700E Chassis Specifications**

---

Overall Width (including rack-mount flanges)	19 1/8 inches
Chassis Width (rack-mount flanges not included)	17 9/16 inches
Height	19 1/4 inches
Height (rack units)	11 RU
Overall Depth (including required fan tray)	17 5/16 inches
Chassis Depth (fan tray not included)	14 3/4 inches
Chassis Weight (fully populated)	128 lbs (58 kg)

# Chassis Slot Numbering

The term *slot* refers to the position at which a CMM or NI module is installed in chassis. CMM slot positions are designated as Slot A and Slot B. On OS9800E switches, NI slot numbers range from 1 to 16. On OS9700E switches, NI slot numbers range from 1 to 8.

Power supply bays are also given specific slot numbers.

On OS9800E switches, power supply slot numbers are designated PS-1 through PS-4 from top to bottom. On OS9700E switches, power supply slot numbers are designated PS-1 through PS-3 from top to bottom.

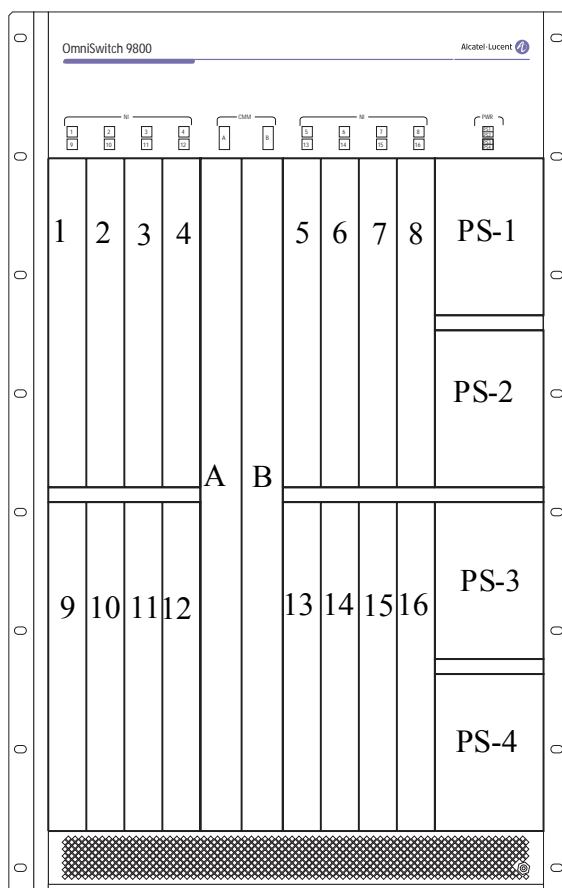

**OS9800E (18-Slot Chassis)**

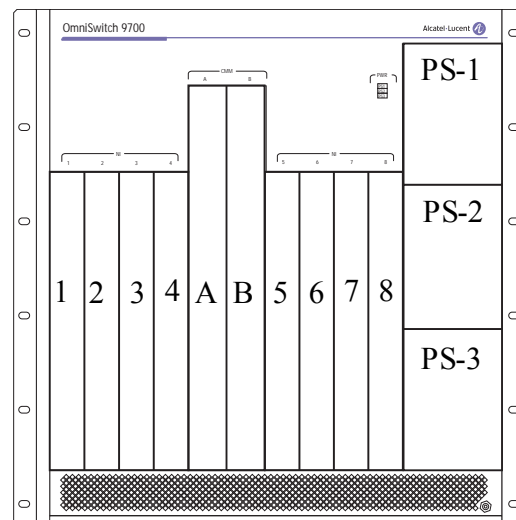

**OS9700E (10-Slot Chassis)**

## Viewing Chassis Slot Information

To view basic slot information via the CLI, enter the **show module** command at the CLI prompt:

```
-> show module
```

To view more detailed slot information, use the **show module long** form of this command. For example:

```
-> show module long
```

## Mounting the Switch

---

**Important.** Two people are required when lifting the chassis. Due to its weight, lifting the chassis unassisted can cause personal injury. If you need to move the switch, be sure to power it down and remove all modules and power supplies. For instructions on removing CMM or NI modules, refer to [Chapter 4, “Network Interface \(NI\) Modules.”](#) For instructions on removing power supplies, refer to [“Removing a Power Supply” on page 2-27.](#)

---

---

**Note.** Due to their weight and airflow requirements, OmniSwitch 9000E Series switches cannot be wall-mounted.

---

### Airflow Considerations

Be sure that your switch is placed in a well-ventilated, static-free environment. Always allow adequate clearance at the front and sides of the switch, as well as behind the switch’s fan unit (located at the top-rear of the chassis). The following top-view diagram shows recommended minimum clearances for adequate airflow.

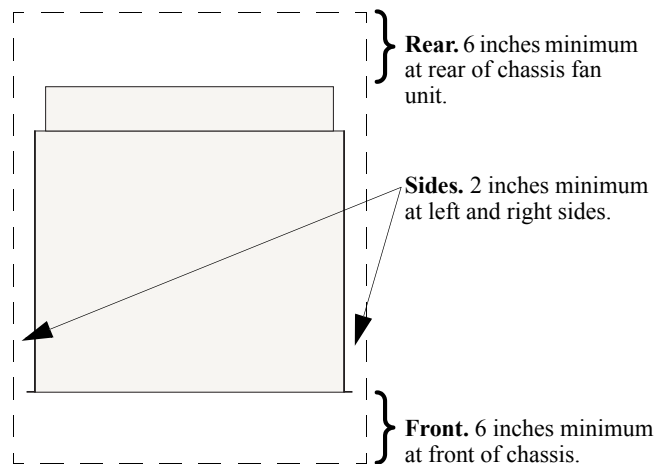

Chassis Top View

---

**Note.** Never obstruct the air intake vents located at the bottom-front and bottom-sides of the chassis *or* the fan unit’s air output vents located at the rear of the chassis. Clearance is not required at the top and bottom of the chassis.

---

## General Mounting Recommendations

**Elevated Operating Ambient** - If installed in a closed or multi-rack assembly, the operating ambient temperature of the rack environment may be greater than room ambient. Therefore, consideration should be given to the maximum rated ambient temperature (T<sub>mra</sub>) specified in the specifications table.

**Reduced Air Flow** - Installation of the equipment in a rack should be such that the amount of air flow required for safe operation of the equipment is not compromised.

**Mechanical Loading** - Mounting of the equipment in the rack should be such that a hazardous condition is not achieved due to uneven loading.

**Circuit Overloading** - Consideration should be given to the connection of the equipment to the supply circuit and the effect that overloading of circuits could have on overcurrent protection and supply wiring. Appropriate consideration of equipment nameplate ratings should be used when addressing this concern.

**Reliable Earthing** - Reliable earthing of rack-mounted equipment should be maintained. Particular attention should be given to supply connections other than direct connections to the branch. (e.g. use of power strips).

## Rack-Mounting

Refer to the important guidelines below before installing an OmniSwitch 9000E Series chassis in a rack.

- Be sure that all modules and power supplies are removed before rack-mounting the switch. For instructions on removing CMM or NI modules, refer to [Chapter 4, “Network Interface \(NI\) Modules.”](#) For instructions on removing power supplies, refer to [“Removing a Power Supply” on page 2-27.](#)
- Rack-mounting the chassis requires three people—two people to hold the chassis and position it in the rack and a third person to secure the chassis to the rack using the attachment screws.
- The chassis has two integral rack-mount flanges that support standard 19-inch rack mount installations. Refer to [page 2-12](#) for information on optional rack-mounting hardware.
- Alcatel-Lucent does not provide rack-mount screws. Use the screws supplied by the rack vendor.
- To prevent a rack from becoming top heavy, it is recommended that you install the switch at the bottom of the rack whenever possible.
- If you are installing the switch in a relay rack, be sure to install and secure the rack per the rack manufacturer’s specifications.
- Refer to [page 2-9](#) for important chassis airflow recommendations before installing.

To rack-mount the switch, follow the steps below:

- 1** Mark the holes on the rack where the chassis is to be installed.
- 2** Using two people, lift and position the chassis until the rack-mount flanges are flush with the rack post.
- 3** Align the holes in the flanges with the rack holes you marked in step 1.

- 4** Once the holes are aligned, use a third person to insert a screw through the *bottom hole on each flange*. Tighten both screws until they are secure.

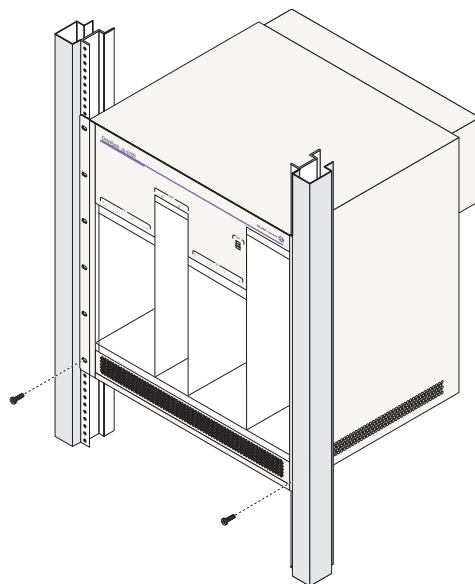

---

**Note.** Be sure to install the screws in the *bottom hole* of each flange, as shown, before proceeding.

---

**5** Once the screws at the bottom of each flange are secure, install the remaining screws. Be sure that all screws are securely tightened.

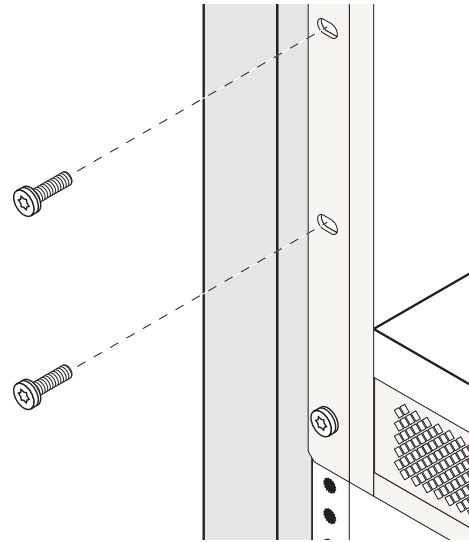

### Optional Rack-Mounting Hardware

All OmniSwitch 9000E switches are shipped with integral front rack-mount flanges. These flanges support standard 19-inch rack mount installations. If you have non-standard rack-mount requirements, Alcatel-Lucent offers optional hardware for the following applications:

- 23-inch rack installations
- Side-mount hardware for additional support

For information on this optional rack mounting hardware, contact your Alcatel-Lucent representative.

### Standalone

The OmniSwitch 9000E Series can be installed unmounted as a standalone unit. Be sure that the installation location is a stable, flat surface that can accommodate the *fully-populated* weight of all switches being installed.

To install the switch as a standalone unit, follow the steps below:

- 1** Use two or more people to move and position the unpopulated chassis upright on the floor or bench where it is to be installed.
- 2** Be sure that adequate clearance has been provided for chassis airflow and that you have placed the chassis within reach of all required AC outlets. For recommended airflow allowances, refer to [page 2-9](#).

---

**Note.** For detailed information on installing additional components and connecting the switch, refer to the *OmniSwitch 9000E Getting Started Guide*.

---

# Power Supplies

The OmniSwitch 9800E supports a total of four power supplies and the OmniSwitch 9700E supports a total of three power supplies (refer to [page 2-24](#) for important redundancy information). The power supplies are installed in the power supply bays located at the right side of the chassis. See [page 2-8](#) for a slot diagram showing the power supply bays.

## AC OK (Top LED).

Displays solid green when the power supply's AC current status is OK and the power supply is operating. Off when the power supply is not operating.

## DC OK (Middle LED).

Displays solid green when the power supply's DC current status is OK and the power supply is operating. Off when the power supply is not operating.

**OVER TEMP (Bottom LED).** Off when the power supply is operating under supported temperature conditions.

Displays solid amber when a temperature error is detected in the power supply housing. If a temperature error is detected, check for an airflow obstruction at the air intake vent or at the back of the chassis. If no airflow obstruction exists, remove or replace the power supply immediately. Refer to the sections below for important information on replacing power supplies and power supply redundancy.

## Power Supply LEDs

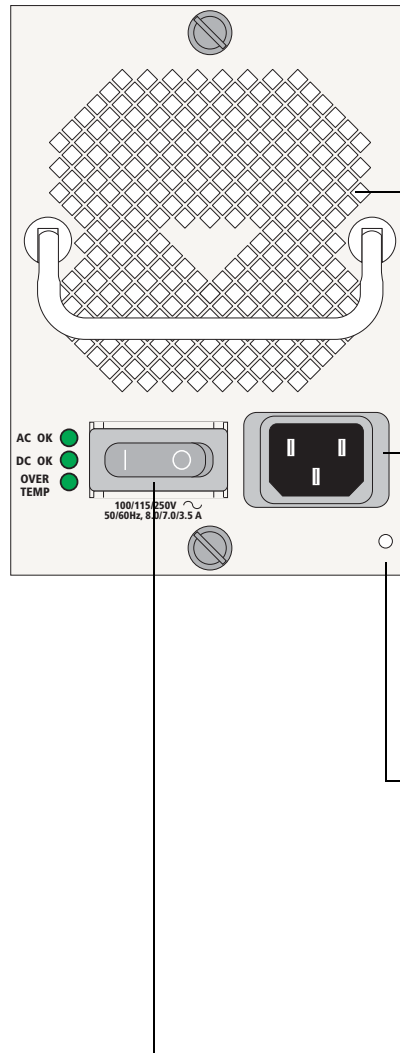

**Air Intake Vent.** The air intake vent provides cooling and temperature control for the power supply. Maintain a front clearance of at least six inches to ensure proper airflow.

For additional airflow information, refer to [page 2-36](#).

**Power Connector Socket.** Type IEC-320-C13. Supports one 10 amp power cord.

It is recommended that you use Alcatel-Lucent provided power cords.

## Power Cord Retainer.

Alcatel-Lucent provides a white nylon cable retainer with each power supply. This retainer is used to secure the power cord so that it cannot be accidentally pulled from the socket. For information on using this retainer, refer to [page 2-26](#).

## Power Switch.

| indicates **on** position;  
○ indicates **off** position.

**Power Supply Front Panel**

---

**OmniSwitch 9000E Power Supply Technical Specifications**

---

Model	OS9-PS-0600A
Input Voltage	100/115/220/230 V
Input Current	12/11/9/9 A
Input Frequency	50/60Hz
Output Power	600 W DC
Output Voltage	25 V DC
Output Current	25 A DC
Width	3.725 inches
Height	5.25 inches
Depth	13.313inches
Weight	6 lbs (2.72 kg)
Ambient Temperature	0 - 70° C (operating) -40 - 85° C (non-operating)
Humidity	5% to 90% Relative Humidity (Operating) 0% to 95% Relative Humidity (Storage)
Altitude	10,000 feet @ 32° C (operating) 50,000 feet (non-operating)

---



## 600 Watt DC-to-DC Power Supply

In addition to AC power supplies, OmniSwitch 9000E switches offer DC power support (OS9-PS-0600D). As with the AC power supplies, DC supplies are installed in the power supply bays located along the right side of the chassis. See [page 2-8](#) for a slot diagram showing the power supply bays.

### DC IN OK (Top LED).

Displays solid green when the power supply's DC *input* status is OK and the power supply is operating. Off when the power supply is not operating.

### DC OUT OK (Middle LED).

Displays solid green when the power supply's DC *output* status is OK and the power supply is operating. Off when the power supply is not operating.

**OVER TEMP (Bottom LED).** Off when the power supply is operating under supported temperature conditions.

Displays solid amber when a temperature error is detected in the power supply housing. If a temperature error is detected, check for an airflow obstruction at the air intake vent or at the back of the chassis. If no airflow obstruction exists, remove or replace the power supply immediately. Refer to the sections below for important information on replacing power supplies and power supply redundancy.

### Safety Ground Connector.

A safety ground is provided on each power supply and is used to ground the OS9000 chassis.

For information on properly connecting the ground, refer to [page 2-26](#).

### Power Supply LEDs

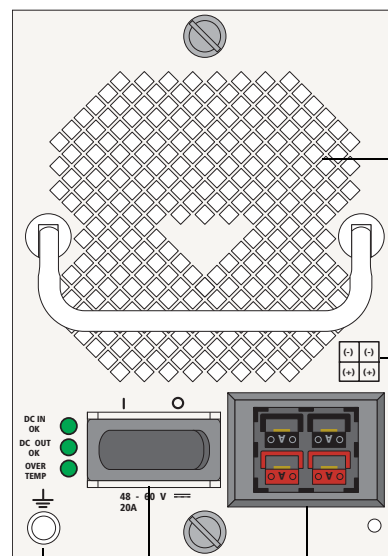

**Air Intake Vent.** The air intake vent provides cooling and temperature control for the power supply. Maintain a front clearance of at least six inches to ensure proper airflow.

For additional airflow information, refer to [page 2-36](#).

**Polarity Indicator Graphic.** Shows location of negative (-) and positive (+) polarity connectors on DC socket.

**DC Power Connector Socket.** Anderson Powerpole modular connector, or equivalent. The connector socket ships factory-installed in the power supply's front panel.

For information on the DC power connectors, including notes on connecting the power cable, refer to [page 2-16](#).

**Power Switch.**  
 | indicates on position;  
 ○ indicates off position.

**DC Power Supply Front Panel**

---

**OmniSwitch 9000E DC Power Supply Technical Specifications**

---

Model	OS9-PS-0600D
Input Voltage	-48VDC to -60VDC
Output Power	600 W DC
Output Voltage	25 V DC
Output Current	25 A DC
Width	3.725 inches
Height	5.25 inches
Depth	13.313inches
Weight	6 lbs (2.72 kg)
Ambient Temperature	0 - 70° C (operating) -40 - 85° C (non-operating)
Humidity	5% to 90% Relative Humidity (Operating) 0% to 95% Relative Humidity (Storage)
Altitude	10,000 feet @ 32° C (operating) 50,000 feet (non-operating)

---

## DC Power Supply Connection

In the current release, a 15-inch pre-assembled cable harness is shipped with each DC-to-DC power supply. You can plug this cable harness directly into the DC power connector on the power supply. Refer to the important information below before connecting a DC power supply.

### Connecting the DC Cable Harness to the Chassis Power Supply

When plugging in the cable, insert the connector end of the cable harness into the power supply connector until it clicks firmly into place. This is an indication that the connector is secure and properly seated.

### Connecting the DC Cable Harness to the DC Power Source

The other end of the cable harness is bare. Users must assemble and connect this end to the DC power source or to a cable coming from the power source. In addition to following the important guidelines listed below, be sure to consult specifications for the DC power source more information.

- Connect the power supply to a reliably grounded 48VDC SELV source.
- The branch circuit overcurrent protection must be rated 30A.
- Use 10AWG copper conductors.
- A readily accessible disconnect device that is suitably approved and rated shall be incorporated in the field wiring.
- The power supply shall be installed in a restricted access location.
- The power supply shall used with an Anderson Power Products model 1460G1 cord connector body.

## Chassis Power Supply Module Support

This table provides *general* guidelines only and applies to most chassis hardware configurations. These guidelines offer a quick way to determine the minimum number of power supplies required for the current chassis configuration. For a definitive approach to determining the minimum amount of power required, *you must follow the steps outlined in “Monitoring Chassis Power” on page 2-18.*

	OS9700E	OS9800E
<b>One Power Supply</b>	Supports one or two CMMs and up to seven NI modules.	Supports one or two CMMs and up to six NI modules.
<b>Two Power Supplies</b>	Supports one or two CMMs and up to eight NI modules.	Supports one or two CMMs and up to 16 NI modules.
<b>Three Power Supplies</b>	Provides power supply redundancy.	Provides power supply redundancy (if only <i>one</i> power supply is removed or goes down unexpectedly). Refer to <a href="#">page 2-24</a> for more information on power supply redundancy.
<b>Four Power Supplies</b>	N/A	Provides complete power supply redundancy (if up to <i>two</i> power supplies are removed or go down unexpectedly). Refer to <a href="#">page 2-24</a> for more information on power supply redundancy.

# Monitoring Chassis Power

Adding Network Interface (NI) modules and removing power supplies significantly affects the overall power budget for the switch. Therefore, before adding a module or removing a power supply, you must first verify that the current chassis power supports the change.

Refer to the sections below for important information on monitoring the current chassis power.

## Checking Chassis Power Before Adding a Module

Depending on the module type, adding a module will increase the required watts to the existing chassis power requirements. The table below shows the requirements for CMM and NI modules currently supported on the OmniSwitch 9000E Series switches.

Module Type	Power Required, in Watts
OS9800E-CMM	40
OS9700E-CMM	27
OS9-GNI-C24E	51
OS9-GNI-U24E	55
OS9-XNI-U2E	55

---

**Note.** Technical specifications for NI modules are provided in [Chapter 4, “Network Interface \(NI\) Modules.”](#)

---

As soon as a module is inserted, and the module’s connectors make contact with the chassis backplane, the power requirements take effect. If there is no adequate power, the incoming module will not power on. Additional power errors may also occur, which can interrupt data flow on the switch. Therefore, it is important to manually check the current chassis power *before* adding a module.

For examples, showing effective ways to check the current chassis power, refer to the examples beginning on [page 2-19](#).

## Example 1: Adequate Power to Add a Module

- 1 First, enter the **show chassis** command. A screen similar to the following displays:

```
-> show chassis
Model Name:          OS9700E,
Description:         OS9700E,
Part Number:         901748-ÿÿÿ,
Hardware Revision:   202,
Serial Number:       1467014A,
Manufacture Date:    NOV 16 2005,
Admin Status:        POWER ON,
Operational Status:  UP,
Free Slots:          8,
Power Left:          535,
Number Of Resets:    2
```

Note that the “Power Left” field in the table output shows 535. This value, displayed in watts, indicates that 535 watts are available for additional hardware (e.g., CMM and NI modules).

- 2 Next, tabulate the power requirements for all modules to be added. Let’s assume the total power required for all incoming modules is 231 watts. Even after the 231 watts are allocated to the incoming modules, the chassis will retain 304 unused watts. The modules can be safely added to the chassis.
- 3 After the modules have been installed, re-enter the **show chassis** command to confirm the results:

```
-> show chassis
Model Name:          OS9700E,
Description:         OS9700E,
Part Number:         901748-ÿÿÿ,
Hardware Revision:   202,
Serial Number:       1467014A,
Manufacture Date:    NOV 16 2005,
Admin Status:        POWER ON,
Operational Status:  UP,
Free Slots:          3,
Power Left:          304,
Number Of Resets:    2
```

As shown in the display, there are 304 watts of unused power in the chassis power supply budget. In this scenario, there was adequate power to add all NI modules, as well as the OS9700E-CMM.

## Example 2: Inadequate Power to Add a Module

- 1 Enter the **show chassis** command. A screen similar to the following displays:

```
-> show chassis
Model Name:           OS9700E,
Description:          OS9700E,
Part Number:          901748-ÿÿÿ,
Hardware Revision:    202,
Serial Number:        1467014A,
Manufacture Date:     NOV 16 2005,
Admin Status:         POWER ON,
Operational Status:   UP,
Free Slots:           8,
Power Left:           40,
Number Of Resets:     2
```

Note that the “Power Left” field in the table output shows 40. This value, displayed in watts, indicates that only 40 watts are available for additional hardware.

- 2 Tabulate the power requirements for the module(s) to be added. For example, let’s say that the module to be added to the chassis consumes 67 watts:

If the module is installed, the switch’s power budget will exceed by *at least 27 watts*. The module *will not* be powered on until:

- One or more modules are removed from the chassis and the switch is rebooted
- or*
- An additional power supply is added (if applicable) and the switch is rebooted

---

**Note.** If a module of the same type is already installed in the chassis, you can use the **show ni** command to determine the power requirements for the module to be added. For example, if an OS9-GNI-C24E is to be added to the chassis, and there is already an OS9-GNI-C24E installed at slot 8, enter the following command:

```
-> show module long 8
Module in slot 8
Model Name:           OS9-GNI-C24E,
Description:          24pt 10/100/1000 Mod,
Part Number:          901765-10,
Hardware Revision:    413,
Serial Number:         1453410A,
Manufacture Date:     NOV 16 2005,
Firmware Version:     5,
Admin Status:         POWER ON,
Operational Status:   UP,
Power Consumption:    51,
Power Control Checksum: 0x808,
MAC Address:          00:d0:95:6b:0b:30,
ASIC - Physical:      0x1901 0x0201 0x0201 0x001e 0x001e 0x001e
```

Note that the module's power requirement is 67 watts, as shown in the "Power Consumption" field.

---

## Checking Chassis Power Before Shutting Off or Removing a Power Supply

When shutting off or removing a power supply, it is important to remember that you are reducing the amount of watts available for NI and CMM modules. In other words, disabling a power supply significantly affects the switch's overall power budget.

Before shutting off or removing a power supply, note that an AC power supply provides approximately *480 usable watts*. Therefore, when removing a power supply, you must first verify that enough watts will be maintained by the remaining power supplies to support the number of modules installed.

### Example 1: Adequate Power to Remove a Power Supply

**1** Enter the **show chassis** command. A screen similar to the following displays:

```
-> show chassis
Model Name:           OS9700E,
Description:          OS9700E,
Part Number:          901748-ÿÿÿ,
Hardware Revision:    202,
Serial Number:        1467014A,
Manufacture Date:     NOV 16 2005,
Admin Status:         POWER ON,
Operational Status:   UP,
Free Slots:           8,
Power Left:           535,
Number Of Resets:     2
```

In this example, the “Power Left” field displays 535 unused watts. If one power supply is removed, the switch will have 55 unused watts ( $535 - 480 = 55$ ). This is adequate power to support the current modules installed; one power supply can be safely removed.

**2** After the modules have been installed, re-enter the **show chassis** command to confirm the results:

```
-> show chassis
Model Name:           OS9700E,
Description:          OS9700E,
Part Number:          901748-ÿÿÿ,
Hardware Revision:    202,
Serial Number:        1467014A,
Manufacture Date:     NOV 16 2005,
Admin Status:         POWER ON,
Operational Status:   UP,
Free Slots:           8,
Power Left:           55,
Number Of Resets:     2
```

---

**Important Power Supply Redundancy Recommendation.** It is strongly recommended that the switch maintains power supply redundancy whenever possible. Refer to [“Power Supply Redundancy” on page 2-24](#) for detailed information on power supply redundancy.

---



## Example 2: Inadequate Power to Remove a Power Supply

- 1 Enter the **show chassis** command. A screen similar to the following displays:

```
-> show chassis
Model Name:          OS9700E,
Description:         OS9700E,
Part Number:         901748-ÿÿÿ,
Hardware Revision:   202,
Serial Number:       1467014A,
Manufacture Date:    NOV 16 2005,
Admin Status:        POWER ON,
Operational Status: UP,
Free Slots:          8,
Power Left:          400,
Number Of Resets:    2
```

In this example, the “Power Left” field displays 400 unused watts. If one power supply is disabled, the switch’s power budget will be exceeded by *at least 80 watts* ( $400 - 480 = -80$ ). If a power supply is shut off or removed for any reason, the switch will automatically power down NI modules until the power budget shortfall has been corrected.

## Adding a Power Supply

You can add a power supply to the chassis at any time without disturbing the switch’s network functions. You are not required to power down the switch.

## Hot Swapping a Power Supply

Hot swapping a power supply refers to the action of *replacing* a power supply while the switch is operating. To hot swap a power supply without disrupting switch operations, you must first have power supply redundancy. Otherwise, switch operations may be disrupted.

## Permanently Removing a Power Supply

If you plan to permanently remove a power supply from the chassis while the switch is operating, verify that you have effective power supply redundancy before doing so. Otherwise, switch operations may be disrupted.

---

**Additional Information.** For instructions on installing and removing power supplies, refer to [page 2-25](#) through [page 2-27](#). For information on power supply redundancy, refer to “Power Supply Redundancy” on [page 2-24](#).

---

# Power Supply Redundancy

While the switch is running, all power supplies installed and operating share the electrical load. If a power supply is physically removed from the chassis or fails unexpectedly, the remaining power supplies automatically take up the load without disrupting the switch. However, for this failover to work, you must have at least one redundant power supply installed and running in your switch at all times. Refer to the important information on [page 2-15](#) through [page 2-23](#) to determine minimum switch power requirements, as well as redundant power supply requirements.

## Redundancy Defined

Power supply redundancy is defined as having at least one power supply more than the minimum switch requirement.

In the example below, a minimum of two power supplies is required to support the switch's basic operations (see [page 2-15](#)). A third power supply provides failover (i.e., *redundancy*) if one power supply is physically pulled from the chassis or quits unexpectedly.

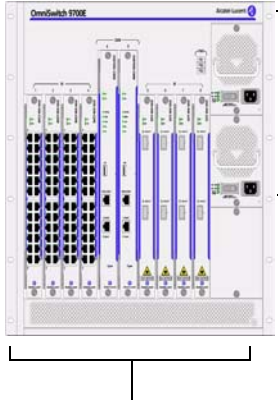
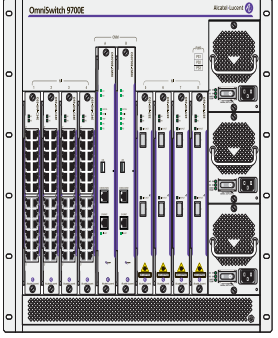
 <p>Two Power Supplies Installed</p> <p>Eight NI Modules and Redundant CMMs Installed</p>	<p><b>Non-Redundant Power Configuration.</b> The OS9700E switch illustrated on the left contains both primary and redundant CMMs, as well as eight NIs (four OS9-GNI-C24E modules and four OS9-XNI-U2E). Note that the chassis contains two power supplies.</p> <p>According to the general guidelines listed on <a href="#">page 2-15</a>, an OS9700E switch with eight NIs requires a minimum of two power supplies for basic switch operations. The example shown at left does not have power redundancy. If a power supply is physically removed from the chassis or fails unexpectedly, switch operations may be disrupted.</p>
 <p>Three Power Supplies Installed</p>	<p><b>Redundant Power Configuration.</b> A third power supply has been added to the same switch. This exceeds the switch's minimum requirement of two power supplies as outlined on <a href="#">page 2-15</a>.</p> <p>The switch has power redundancy. If one power supply is removed from the chassis or fails unexpectedly, the redundant supply will help carry the load requirements. Switch operations will not be disrupted.</p> <p><b>Note.</b> The table on <a href="#">page 2-15</a> provides general power supply guidelines only. To verify that your switch has redundant power, you must follow the steps outlined beginning on <a href="#">page 2-18</a>.</p>

### OS9700E Power Supply Redundancy Example

## Installing a Power Supply

- 1** If there is a blank cover panel over the power supply bay, loosen the two captive screws located at the top and bottom of the blank cover panel. If necessary, use a flat-blade screwdriver to loosen the screws. Set the blank cover panel aside.
- 2** Be sure that you do not attempt to install the power supply upside down. When orienting the power supply, note that the on/off switch and power cord socket are located at the *bottom* of the power supply and the fan is located at the *top* of the power supply.
- 3** With one hand, grasp the handle at the front of the power supply. Place your other hand under the power supply casing to support its weight.
- 4** Carefully insert the rear of the casing into the power supply bay and slide the power supply back until its connector meets the chassis backplane connector.

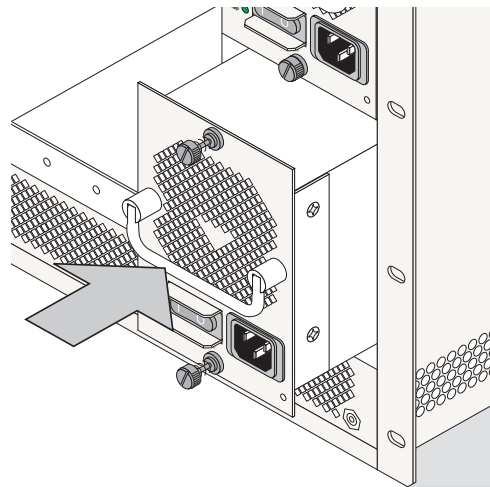

- 5** Continue sliding the power supply back until the front panel meets the front of the chassis. *Do not force the power supply into the bay. Otherwise you can damage the connectors.*

**6** Tighten the two captive screws, located at the top and bottom of the power supply's front panel. *Be sure not to overtighten the captive screws. If you use a screwdriver, the torque used to tighten the screws must not exceed 2.3 foot-pounds.*

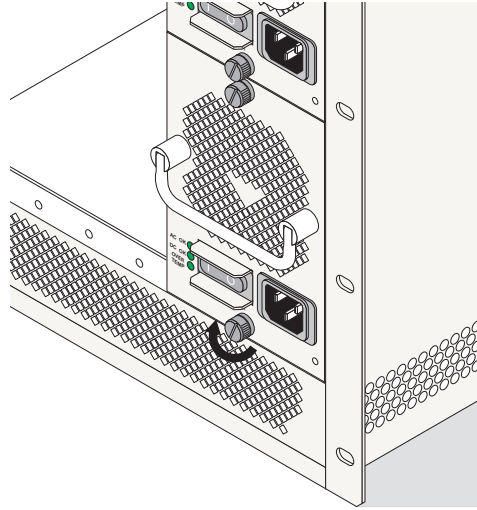

**7** Verify that the power supply's on/off switch is in the off (O) position.

**8** Loop the AC power cord (provided) once through the white nylon cable retainer located on the power supply's front panel and secure the retainer using the butterfly fastener. By looping the power cord through this retainer, the cord cannot be accidentally pulled from the socket.

**9** Once the power cord is looped through the retainer, plug the power cord connector into the power supply's socket and then plug the power cord into an easily-accessible, *properly grounded* outlet. *Do not use an extension cord.*

## Removing a Power Supply

- 1** Before removing a power supply, make sure that the power switch is in the off (O) position. Unplug the power cord from the AC socket, as well as from the socket on the power supply's front panel.
- 2** If necessary, remove the power cord from the white cord retainer on the power supply's front panel.
- 3** Loosen the two captive screws, located at the top and bottom of the power supply's front panel. If necessary, use a flat-blade screwdriver to loosen the screws. Be sure that both captive screws are completely disengaged from the threaded holes in the chassis before continuing.

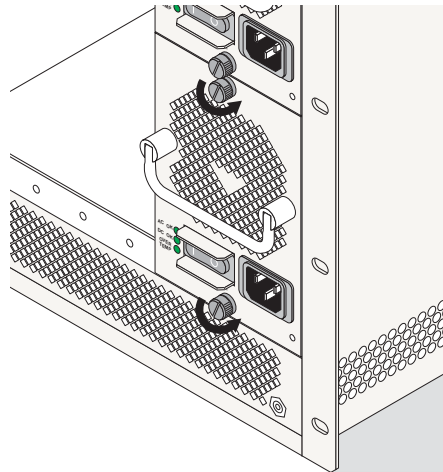

- 4** With one hand, grasp the handle at the front of the power supply and slowly pull the power supply out of the power supply bay. *Do not pull the power supply completely out of the bay with one hand.*

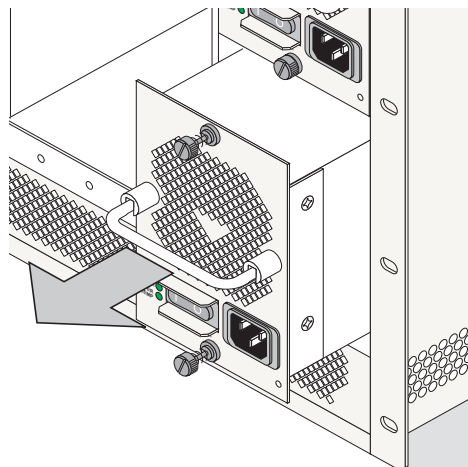

- 5** When the power supply is pulled out far enough (about 10"), place your other hand under the power supply casing to support its weight.
- 6** Continue pulling the power supply out until it is removed from the chassis.
- 7** If you are not replacing the power supply, be sure to install a blank cover panel over the empty power supply bay. To install a blank cover panel, place it over the empty power supply bay and align the panel's two captive screws with the threaded holes in the chassis. Once the captive screws are aligned, fasten the blank cover panel to the chassis. *Be sure not to overtighten the captive screws. If you use a screwdriver, the torque used to tighten the screws must not exceed 2.3 foot-pounds.*

# Power Cords

Because the power cord is the power supply's main disconnect device, it should be plugged into an easily accessible outlet. In the event that your power cord is lost or damaged, refer to the specifications below.

## Specifications

The power cord to be used with 115-Volt configuration is a minimum type SJT (SVT) 14/3, rated at 250 Volts AC, 10 Amps with a maximum length of 15 feet. One end terminates in an IEC 320 attachment plug and the other end terminates in a NEMA 5-15P plug.

The power cord to be used with 230-Volt configuration is minimum type SJT (SVT) 14/3, rated 250 Volts ac, 10 Amps with a maximum length of 15 feet. One end terminates in an IEC 320 attachment plug and the other end terminates as required by the country where it will be installed.

European cords must be Harmonized (HAR) type.

---

**Important.** The specified replacement power cord for OmniSwitch 9000E Series switches is 14-gauge (14/3). Do not use standard 18-gauge (18/3) cords such as those supplied with personal computers.

---

## DC-to-DC Power Cords

For DC-to-DC connections, refer to [page 2-16](#) for additional guidelines and information.

# Redundant AC Circuit Recommendation

If possible, it is recommended that each AC outlet resides on a separate circuit. With redundant AC, if a single circuit fails, the switch's remaining power supplies (on separate circuits) will likely be unaffected and can therefore continue operating.

**Note.** The switch must have power supply redundancy for the redundant AC circuit to be effective. Refer to “600 Watt DC-to-DC Power Supply” on page 2-15 for more information.

The diagram below shows a simple redundant AC circuit scenario using an OS9700E switch.

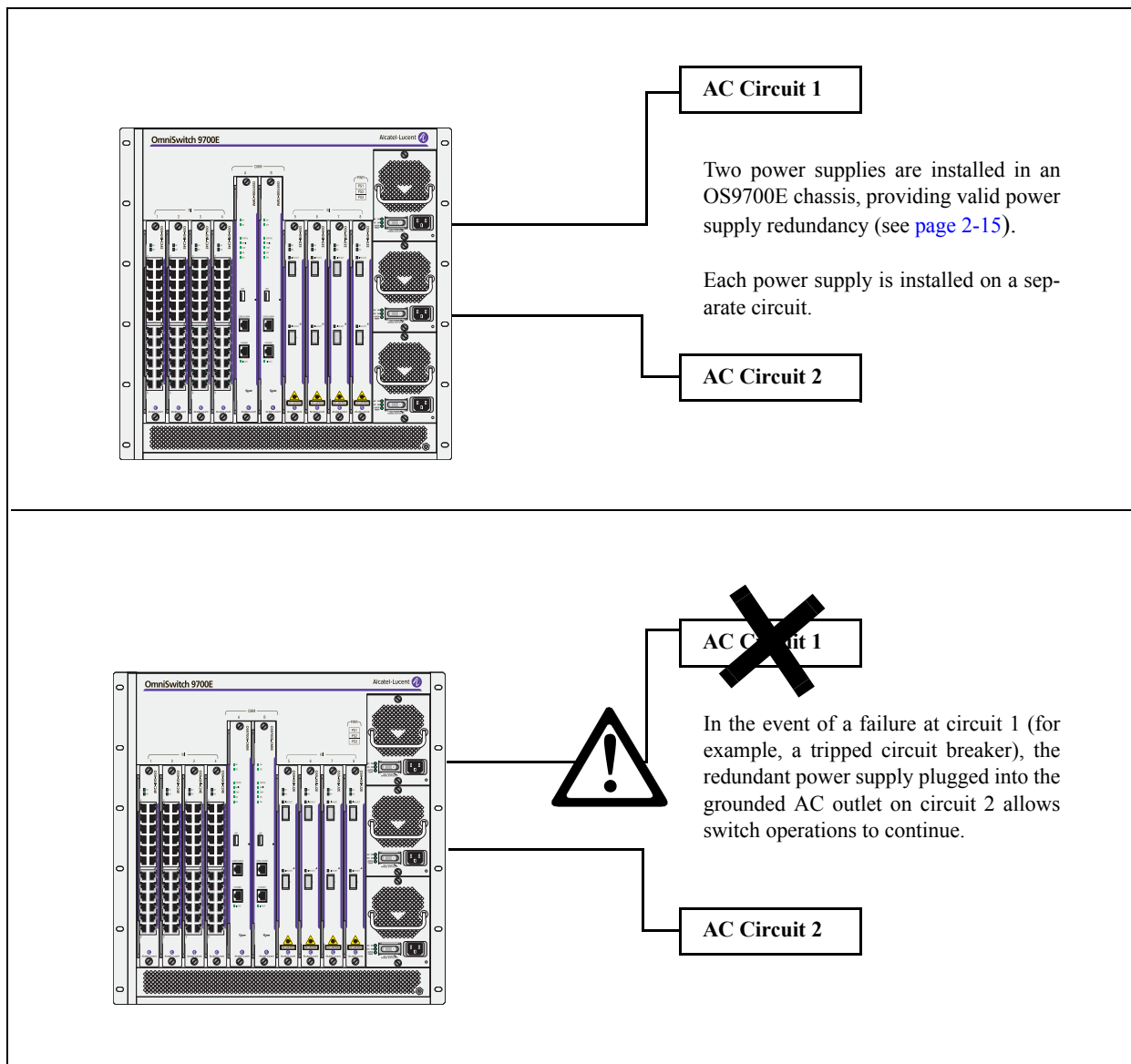

**OS9700E Redundant AC Circuit Example**

## Grounding the Chassis

The switch has two threaded holes for grounding screws located on the back of the chassis. These holes use 10-32 screws and are approximately one inch apart. These holes are surrounded by a small paint-free rectangular area, which provides metal-to-metal contact for a ground connection.

Use this connector to supplement the ground provided by the AC power cord. To do so, install a Panduit Grounding Lug (type LCD8-10A-L) using 8AWG copper conductors to the paint-free rectangular area. The crimping tool required is the Panduit CT-940CH.

## Temperature Management

The operating temperature of your switch is an important factor in its overall operability. In order to avoid a temperature-related system failure, your switch must always run at an operating temperature given in the specifications table.

To avoid chassis over-temperature conditions, follow these important guidelines:

- 1** Be sure that your switch is installed in a well-ventilated environment. To ensure adequate airflow, allow at least six inches of clearance at the front and back of the chassis. In addition, leave at least two inches of clearance at the left and right sides.
- 2** If your switch chassis is not fully populated with NI modules, be sure that blank cover panels are installed at empty slot positions at all times. Blank cover panels help regulate airflow and thus regulate the overall operating temperature in the switch. Refer to [page 2-38](#) for more information.

---

**Monitoring Chassis Temperature Status.** To check the switch's current temperature status, use the [show temperature](#) command. For example:

```
-> show temperature
Hardware Board Temperature (deg C)      = 35,
Hardware Cpu Temperature (deg C)       = 29,
Temperature Upper Threshold Range (deg C) = 30 to 80,
Temperature Upper Threshold (deg C)    = 60,
Temperature Range                       = UNDER THRESHOLD,
Temperature Danger Threshold (deg C)   = 80
```

For more information about these displays, see the “Chassis Management and Monitoring Commands” chapter in the *OmniSwitch CLI Reference Guide*.

---



## Temperature Errors

The CMM monitors the chassis ambient air temperature at all times via an onboard sensor. If an over-temperature condition occurs, there are two different levels of error severity:

- Warning threshold has been exceeded
- Danger threshold has been exceeded

### Warning Threshold

If the temperature exceeds the switch's user-configurable *warning threshold*, the CMM sends out an SNMP trap. Also, traps are printed to the console in the form of text error messages. The CMM's TEMP LED also displays amber, indicating an error. (Refer to [Chapter 2, "Chassis and Power Supplies"](#) for CMM front panel descriptions, including status LEDs.)

When the warning threshold has been exceeded, switch operations remain active. However, it is recommended that immediate steps be taken to address the over-temperature condition.

Addressing warning threshold temperature conditions may include:

- Checking for a chassis airflow obstruction
- Checking the ambient room temperature
- Checking the fan tray status using the [show fan](#) command. See [page 2-33](#) for more information.
- Verifying that the warning threshold has not been manually set to an otherwise common or acceptable ambient temperature—for example, 31degrees Centigrade. (The default warning threshold is 60C. This value may be configured using the [temp-threshold](#) command. The current set warning threshold may be viewed using the [show temperature](#) command.)

---

**Note.** Once the ambient air temperature is reduced to below the warning threshold, the CMM's TEMP LED automatically resets to green.

---

### Danger Threshold

If the chassis ambient air temperature rises above the danger threshold the switch will power off all Network Interface (NI) modules until the temperature conditions have been addressed and the switch is manually booted. The danger threshold is factory-set and cannot be configured by the user.

Addressing danger threshold temperature conditions may include:

- Checking for a chassis airflow obstruction
- Checking the ambient room temperature
- Checking the fan tray status using the [show fan](#) command. See [page 2-33](#) for more information.

---

**Note.** When the danger threshold has been exceeded, the CMM's TEMP LED will not reset from amber to green until after a system boot.

---

# Chassis Fan Tray

The OmniSwitch 9700E and OmniSwitch 9800E switches house a single fan tray located at the top-rear of the chassis. This fan tray consists of three independently-operating fans and is the main temperature control component of the switch. The fan tray provides cooling airflow for all NI modules and CMMs. This airflow is a crucial factor in the switch's overall operability. Refer to [“Chassis Airflow” on page 2-36](#) for an overview of chassis airflow. Also, refer to [page 2-9](#) for important airflow considerations.

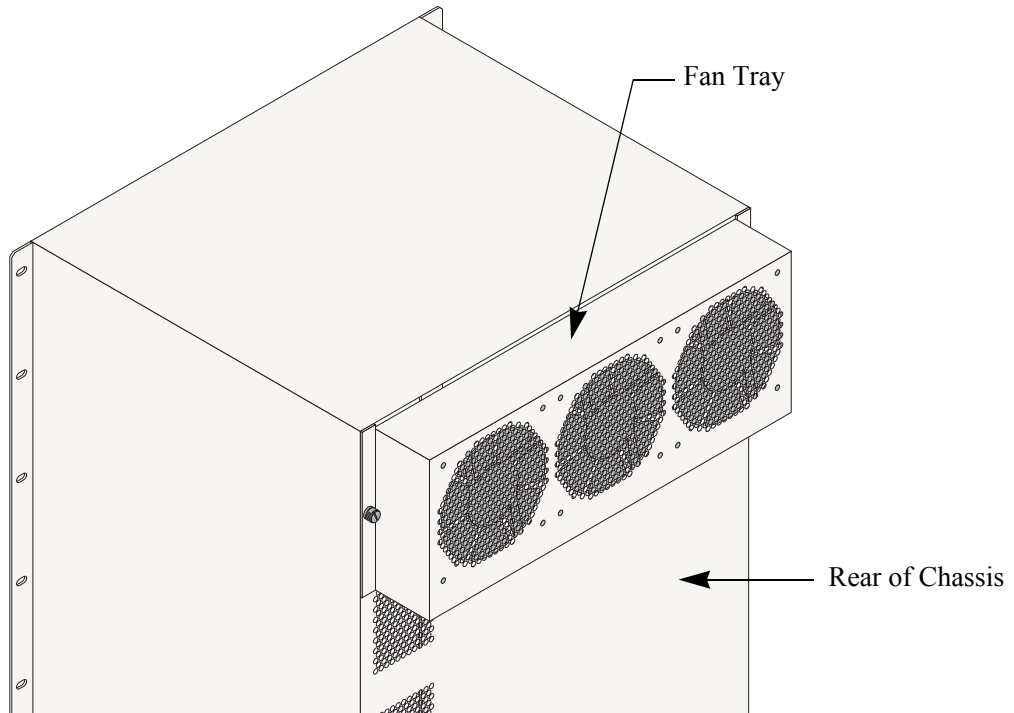

**Fan Tray Location on OS9700E and OS9800E**

---

### Fan Tray Technical Specifications

Power (OS9800E)	107 W (maximum)
Power (OS9700E)	107 W (maximum)

---

**Important.** The fan tray is a required component. Never attempt to operate the switch without the fan tray installed.

---

## Monitoring Fan Tray Status

The CMM constantly monitors fan operation. If any of the switch's fans unexpectedly shuts down, the CMM sends out a trap and the FAN LED on the CMM's front panel displays amber.

---

**Note.** To check the switch's current fan tray status, use the `show fan` command. For example:

```
-> show fan
Fan          Status
-----+-----
Fan-1       Running
Fan-2       Running
Fan-3       Running
```

For more information about these displays, see the “Chassis Management and Monitoring Commands” chapter in the *OmniSwitch CLI Reference Guide*.

---

## Fan Redundancy

In the event that *one* fan quits unexpectedly, the remaining fans will continue running; switch operations are not disrupted.

---

**Note.** One fan failure needs to be reported immediately to have an RMA unit available, and upon receiving the unit it must be replaced immediately. If no action is taken and a second fan fails, the chassis will shutdown all NIs after one minute and fifteen seconds. For information on emergency replacement of the fan tray, refer to “[Hot Swapping the Fan Tray](#)” below.

---

---

**Storing Backup Fan Trays.** It is a good idea to keep at least one backup fan tray in your data facility or other hardware storage area.

---

## Hot Swapping the Fan Tray

As stated previously, the fan tray is the main temperature control component of the switch. As a result, *the fan tray should never be removed while the switch is operating unless it is absolutely necessary*.

However, if the fan tray requires immediate replacement or service, the fan tray can be hot swapped—i.e., it can be changed out without shutting off the switch.

---

**Important.** Hot swapping the fan tray is a time-sensitive procedure. *If the fan tray is removed, it must be replaced within one minute and fifteen seconds.* Otherwise, overheating will occur, which can lead to system failure.

---

For detailed instructions on properly removing and installing a fan tray, refer to [page 2-34](#) through [page 2-35](#).

## Removing the Fan Tray

**1** Begin by loosening the two captive screws located at the left and right sides of the fan tray. Use a flat-head screwdriver, if necessary.

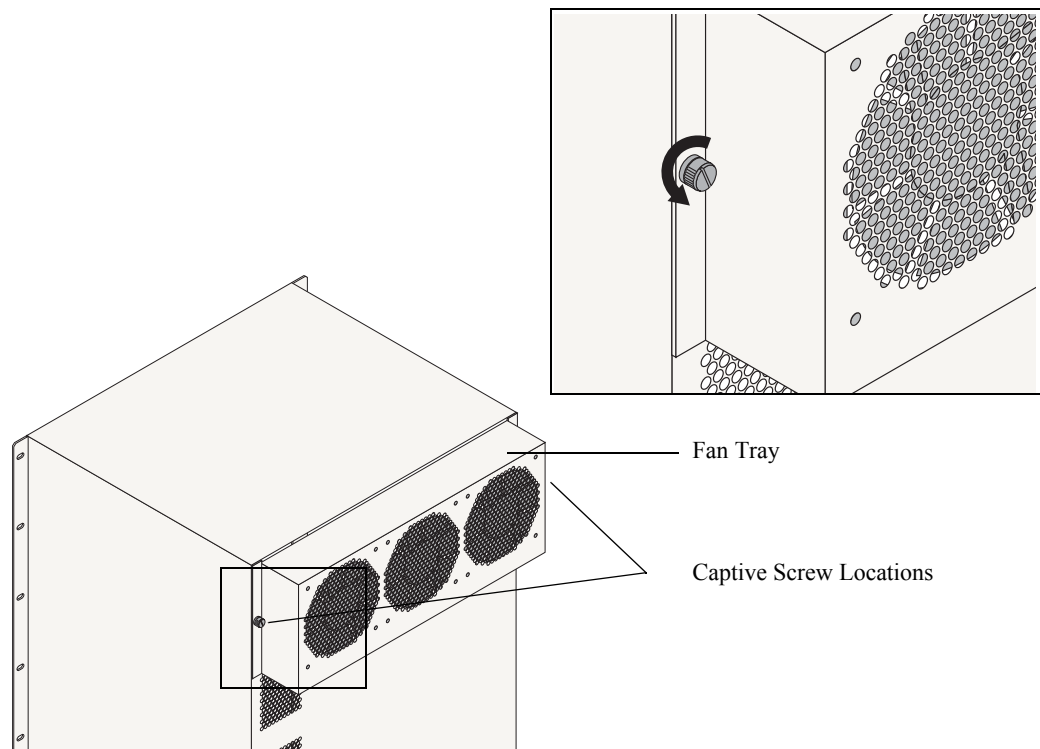

### Loosening the Fan Tray Captive Screws

**2** After the captive screws have been loosened (i.e., disengaged from the threaded holes in the chassis), pull the fan tray straight out from the switch by holding it from the external surface and avoid touching inside the fan tray. Refer to the diagrams below for more information.

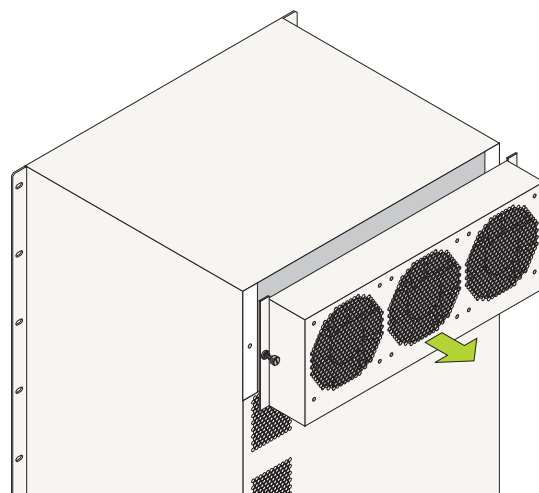

Detach the fan tray by pulling it straight out and away from the chassis.

### Detaching the Fan Tray from the Chassis

## Installing the New Fan Tray

**1** Align the new fan tray's captive screws with the threaded holes at the rear of the chassis. The fan tray has an onboard power connector that plugs into a power connector socket on the chassis. In addition to aligning the captive screws, be sure that this power connector is aligned with the power connector socket on the chassis. Next, push the fan tray straight against the switch chassis.

**Align the Captive Screws.** Align the fan tray's captive screws with the threaded holes in the chassis. Push the fan tray back against the switch chassis.

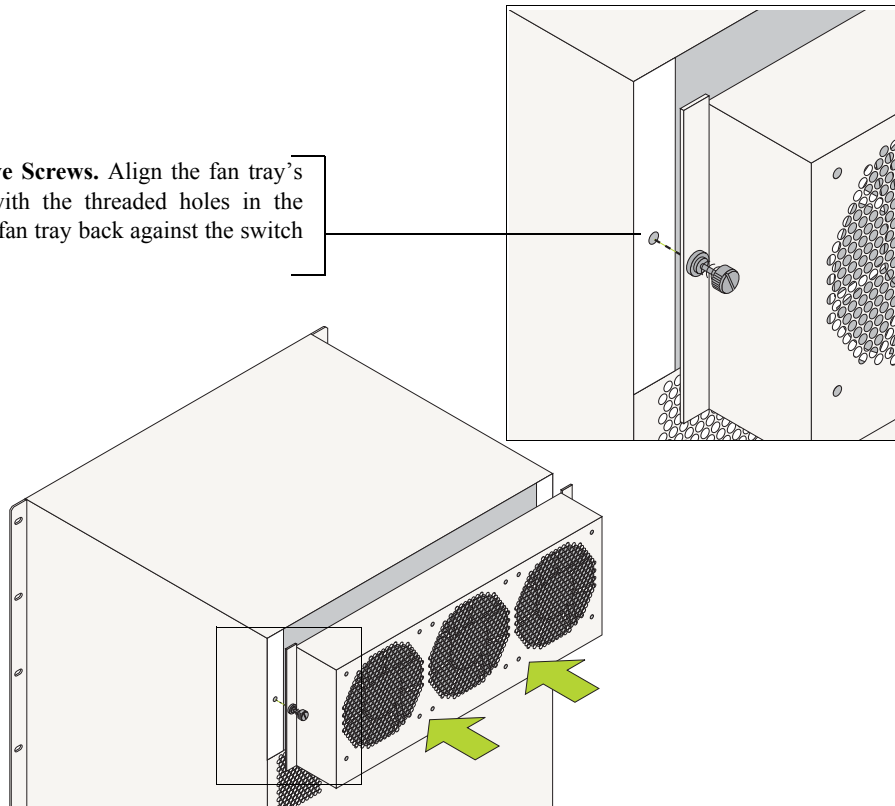

### Aligning the Captive Screws

**2** When the attachment flanges are flush against the chassis rear panel, tighten the captive screws.

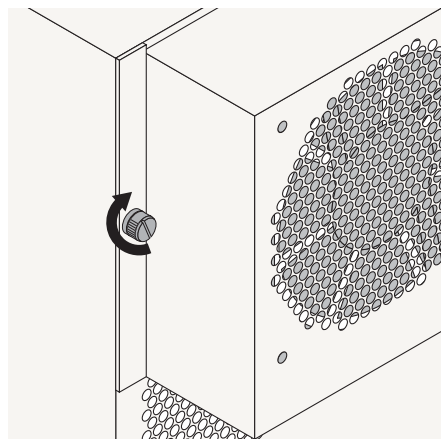

**Tighten the Captive Screws.** When the attachment flanges are flush against the chassis' rear panel, tighten the captive screws.

### Tightening the Captive Screws

# Chassis Airflow

The fan tray pulls air from the air intake vents located at the bottom-front and left and right sides of the chassis. The air is directed vertically through the chassis' module compartment and past the NI and CMM circuit boards. Airflow is then exhausted through the fan tray at the top-rear of the chassis.

---

**Important.** Maintain a clearance of at least six inches at the front and back of the chassis, as well as at the left and right sides. Otherwise, airflow may become restricted. Restricted airflow can cause your switch to overheat; overheating can lead to switch failure.

---

The figure below provides illustrated airflow diagrams for the OmniSwitch 9000E Series switches. See [page 2-38](#) for an airflow diagram describing the chassis' power supply bays.

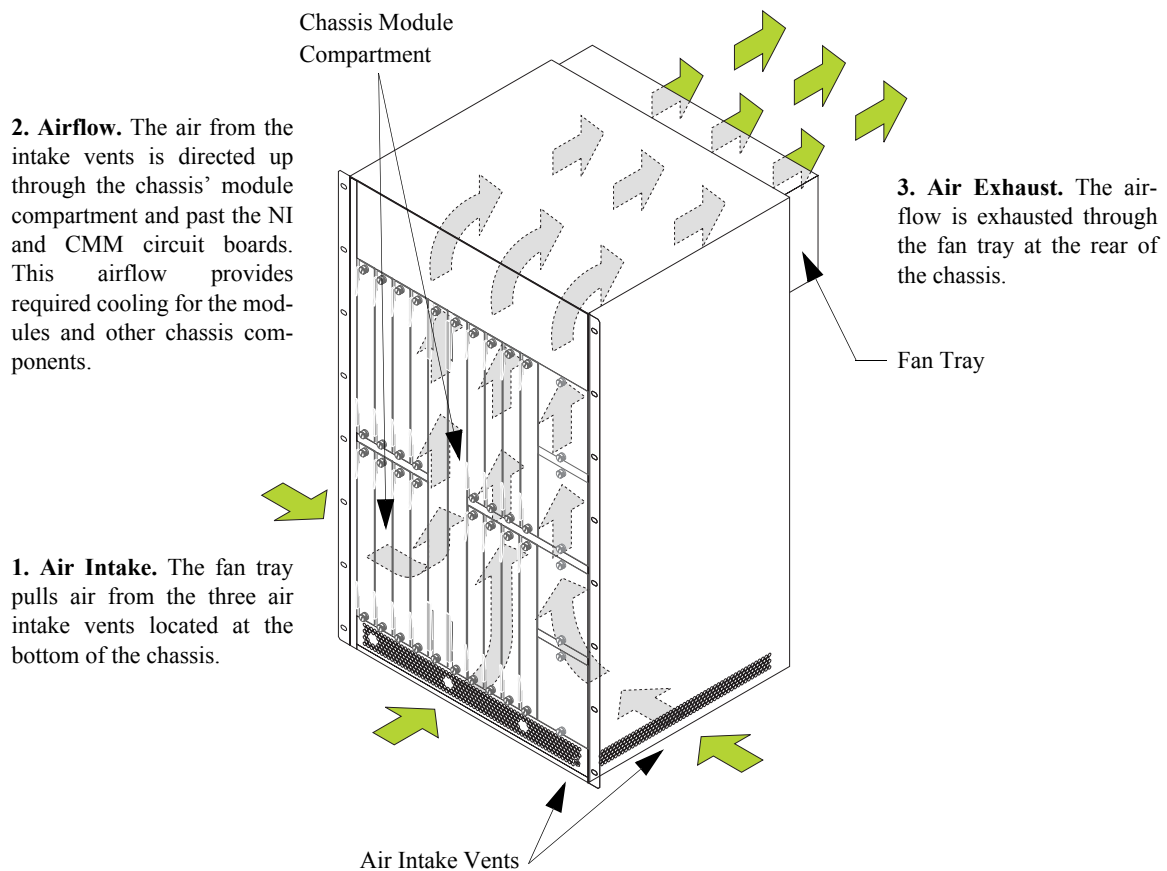

**Airflow for OS9800E Switches**

See [page 2-38](#) for an airflow diagram describing the chassis' power supply bays

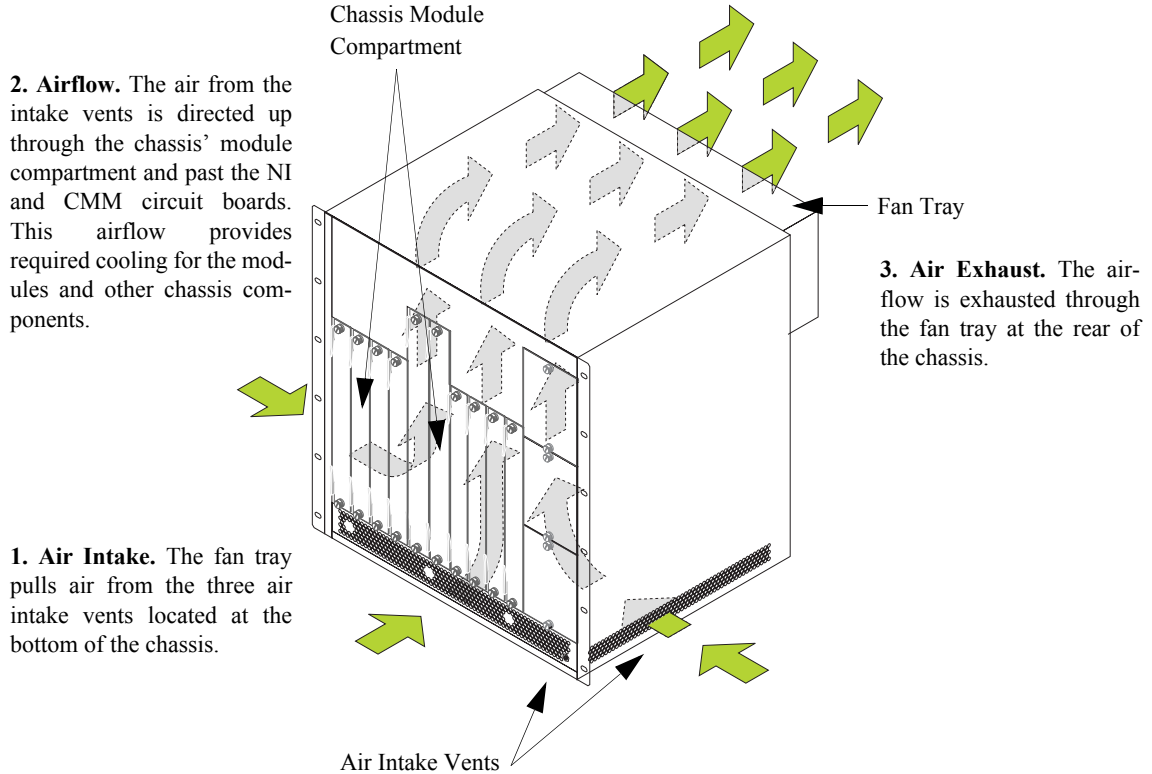

**Airflow for OS9700E Switches**

## Power Supply Fans

The chassis fan tray does not regulate power supply temperature. Instead, a cooling fan is installed in each power supply. Since power supply bays are self-contained, each fan operates independently, cooling only its associated power supply. Refer to the diagram below for more information.

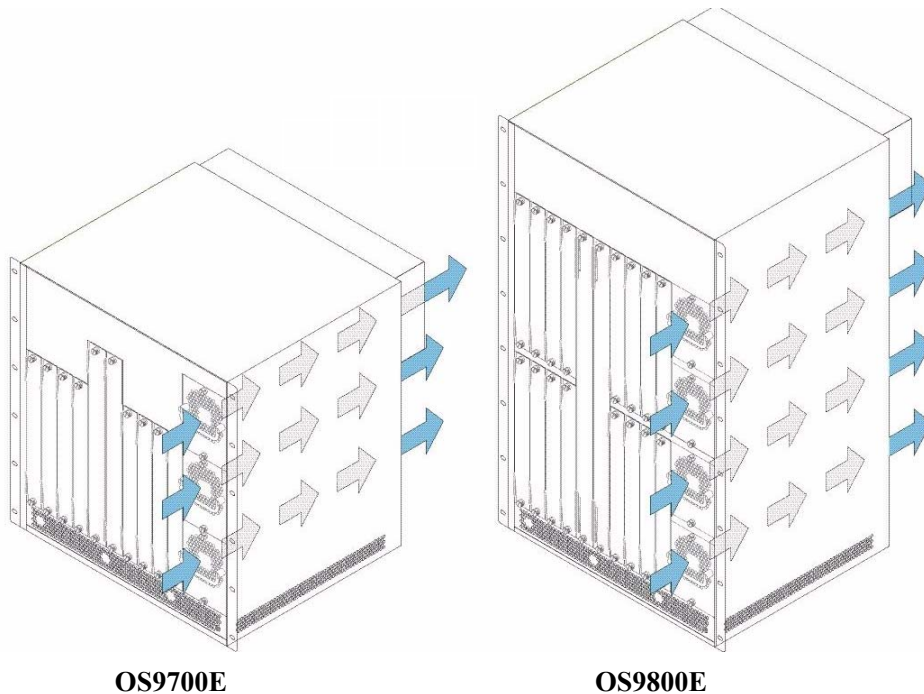

**1. Airflow Intake.** The fan unit, located behind each power supply front panel, pulls air from the air intake vent..

**2. Airflow.** The air from the intake vent is directed front-to-back through the power supply housing. The airflow provides required cooling for the power supply's internal components.

**3. Air Exhaust.** Airflow is exhausted through a corresponding vent in the rear panel of the chassis. Refer to [page 2-2](#) for vent locations.9700E.

### Airflow for Power Supplies

See [page 2-13](#) for detailed power supply front panel and LED information.



## Blank Cover Panels and Chassis Airflow

Blank cover panels are provided with your switch and are used to cover empty CMM and NI slots, as well as empty power supply bays. These cover panels play an important role in chassis airflow and temperature management. If your switch is not fully populated and blank cover panels are *not installed* over empty slot locations, airflow is affected. When blank cover panels are missing, air does not take the direct route from the air intake vents, up through the chassis module compartment, and out through the fan tray. Instead, a portion of the airflow is allowed to be drawn in through the front module compartment of the chassis. As a result, normal airflow is disrupted and an extra task is placed on the fan tray to cool the chassis. Refer to the figure below for more information.

Cover panels also provide protection for module processor boards and other sensitive internal switch components by closing off a chassis that is not fully populated.

---

**Note.** Because they regulate airflow and help protect internal chassis components, blank cover panels should be installed over empty module slots and power supply bays at all times.

---

### Missing Cover Panels.

Missing cover panels affect airflow by allowing air to be drawn in through the front module compartment of the chassis. As a result, the direct route from the air intake vents to the fan tray exhaust is disrupted.

For optimal airflow and chassis component protection, always install blank cover panels over empty module slots and power supply bays.

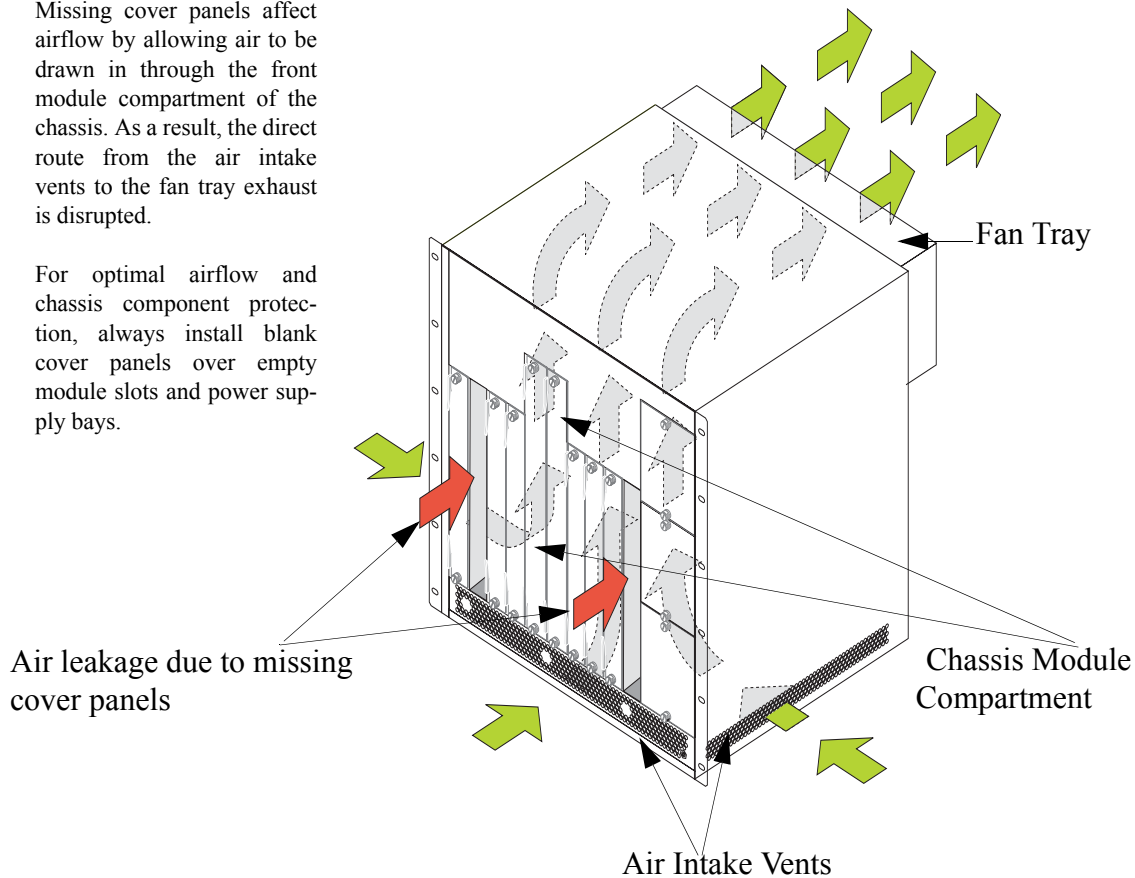

**Effects of Missing Blank Panels on Chassis Airflow**



# 3 Chassis Management Module (CMM)

The Chassis Management Module (CMM) is the management unit for OmniSwitch 9000E Series switches. In its role as the management unit, the CMM provides key system services, including:

- Console, USB, and Ethernet management port connections to the switch
- Software and configuration management, including the Command Line Interface (CLI)
- Web-based management (WebView) management
- Power distribution
- Switch diagnostics
- Important availability features, including redundancy (when used in conjunction with another CMM), software rollback, temperature management, and power management
- The CMM also contains the switch fabric unit for the OmniSwitch 9000E Series switches. Data passing from one NI module to another passes through the CMM fabric. When two CMMs are installed, both fabrics are normally active.

---

**Note.** OmniSwitch 9000E Series 9000E CMMs are colored with a purple stripe to distinguish them from OmniSwitch 7700/7800 CMMs (no coloring) and the OmniSwitch 9700/9800 (colored orange). Do *not* install OmniSwitch 9000E Series and OmniSwitch 7700/7800/9700/9800 CMMs in the same chassis.

---

# CMM Slot Locations

In a non-redundant (i.e., single CMM) configuration, the CMM module can be installed in either Slot A or Slot B of the chassis. In a redundant CMM configuration, a CMM module is installed in both Slot A and Slot B (refer to [page 3-10](#) for more information on CMM redundancy). Both non-redundant and redundant CMM configurations can be performed on OmniSwitch 9000E Series switches.

Note that the CMM slots are longer than the Network Interface (NI) slots. These slots run vertically on the OS9700E and OS9800E chassis9600. They are located near the center of the chassis. Refer to the figures below:

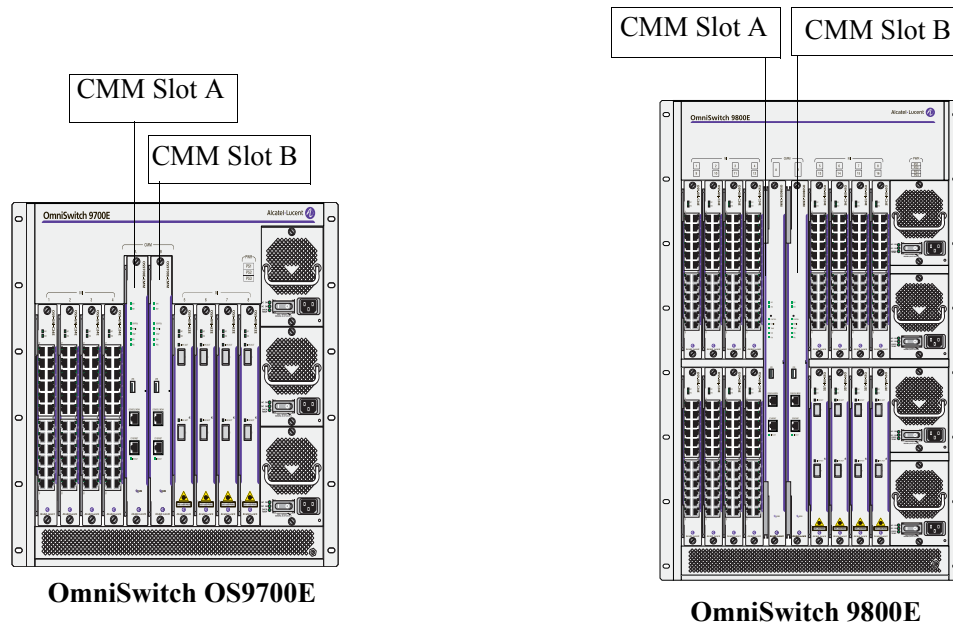

CMM Slot Locations

## OS9700E-CMM Versus OS9800E-CMM

OS9700E-CMM and OS9800E-CMM modules offer identical functions. In addition, OS9700E-CMM and OS9800E-CMM front panels provide the same port configurations and status LEDs. However, there are two notable differences:

- 1** The physical dimensions of the OS9700E-CMM differ from those of the OS9800E-CMM. As a result, OS9700E-CMMs and OS9800E-CMMs are not interchangeable between the OS9700E and 9800E chassis types.
- 2** OS9700E-CMMs and OS9800E-CMMs use identical processor boards. However, OS9800E-CMMs use twice the number of network interface-related ASICs on the fabric board. This is because OmniSwitch 9800E switches support up to 16 network interface (NI) modules and OmniSwitch 9700E switches support up to 8 NI modules.

# CMM Front Panel

## Module Status LEDs

**OK1.** Hardware Status. Displays solid green when powered on and the CMM has passed hardware diagnostic tests. Displays solid amber when powered on and the CMM has failed hardware diagnostic tests.

**OK2.** Software Status. Blinks green when the CMM is operational. Displays solid amber when a system software failure occurs. Blinks amber when the software is in a transitional state (e.g., when software is being downloaded to the switch).

## Control/Fabrics/PSU/Temperature/Fan status LEDs

**CONTROL.** Displays solid green when the CMM is active, blinking green when standby, amber when malfunctioning, and blinking amber for upgrade.

**FABRIC.** Displays solid green when the fabric is active, blinking amber or steady amber for different fabric malfunctions.

**TEMP.** Displays green at 0-40°C, blinking amber at 40-45°C, and solid amber at over 45°C.

**FAN.** Displays solid green when all fans in the fan tray are running at normal speed. Displays solid amber if a fan error occurs (i.e., one or more fans are not running at normal speed).

**PSU.** Displays green when power is OK, blinking amber when one PSU is bad but the chassis has enough power, and solid amber when the chassis does not have enough power.

## Ethernet Management Port LEDs

**LINK.** Link/Activity Status. Displays solid green when an Ethernet cable connection exists at the CMM's Ethernet Management Port. Flashes green as data is transmitted or received.

## Module Status LEDs

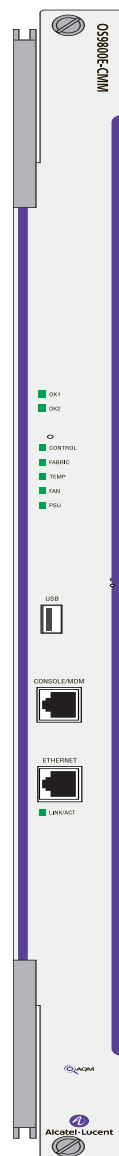

**USB Port.** High speed (480 Mbps) USB 2.0 port, which can be used for quick upgrades.

**Note:** USB port is not supported in this release.

**Console Port.** The CMM's front panel provides one RJ-45 port for console connections. By default, this connector provides a DCE console connection.

**Ethernet Management Port (EMP).** The CMM's front panel also provides one Ethernet 10/100/1000BaseT port (copper RJ-45). This port provides out-of-band network management and can be used for Telnet sessions, switch diagnostics, and for downloading software to the switch.

This 10/100/1000BaseT port supports both 10BaseT, 100BaseT and 1000BaseT with auto-negotiation through the RJ-45 connector.

**Note:** In redundant CMM configurations, the EMP is only operational on the *primary* CMM.

## CMM Front Panel (OS9700E-CMM version shown)

### Module Status LEDs

**OK1.** Hardware Status. Displays solid green when powered on and the CMM has passed hardware diagnostic tests. Displays solid amber when powered on and the CMM has failed hardware diagnostic tests.

**OK2.** Software Status. Blinks green when the CMM is operational. Displays solid amber when a system software failure occurs. Blinks amber when the software is in a transitional state (e.g., when software is being downloaded to the switch).

### Control/Fabrics/PSU/Temperature/Fan status LEDs

**CONTROL.** Displays solid green when the CMM is active, blinking green when standby, amber when malfunctioning, and blinking amber for upgrade.

**FABRIC.** Displays solid green when the fabric is active, blinking amber or steady amber for different fabric malfunctions.

**TEMP.** Displays green at 0-40°C, blinking amber at 40-45°C, and solid amber at over 45°C.

**FAN.** Displays solid green when all fans in the fan tray are running at normal speed. Displays solid amber if a fan error occurs (i.e., one or more fans are not running at normal speed).

**PSU.** Displays green when power is OK, blinking amber when one PSU is bad but the chassis has enough power, and solid amber when the chassis does not have enough power.

### Ethernet Management Port LEDs

**LINK.** Link/Activity Status. Displays solid green when an Ethernet cable connection exists at the CMM's Ethernet Management Port. Flashes green as data is transmitted or received.

### Module Status LEDs

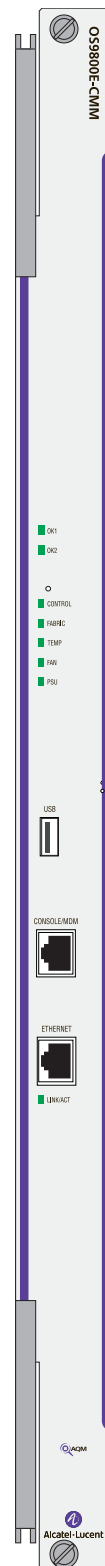

**USB Port.** High speed (480 Mbps) USB 2.0 port, which can be used for quick upgrades.

**Note:** USB port is not supported in this release.

**Console Port.** The CMM's front panel provides one RJ-45 port for console connections. By default, this connector provides a DCE console connection.

### Ethernet Management Port (EMP).

The CMM's front panel also provides one Ethernet 10/100/1000BaseT port (copper RJ-45). This port provides out-of-band network management and can be used for Telnet sessions, switch diagnostics, and for downloading software to the switch.

This 10/100/1000BaseT port supports both 10BaseT, 100BaseT and 1000BaseT with auto-negotiation through the RJ-45 connector.

**Note:** In redundant CMM configurations, the EMP is only operational on the *primary* CMM.

**CMM Front Panel (OS9800E-CMM version shown)**

---

### CMM Technical Specifications

---

Flash memory	256 MB
SIMM (DRAM) memory	1 GB
Console port	One RJ-45 console/modem port; set to console by default
Ethernet management port (EMP)	One RJ-45 port; provides out-of-band network management and can be used for Telnet sessions or for downloading switch software via FTP
USB port	USB 2.0
Power Consumption (OS9700E-CMM)	27 W
Power Consumption (OS9800E-CMM)	40 W
Width (OS9700E)	13.083 inches
Width (OS9800E)	21.375 inches
Height	1.42 inches
Depth	13.024 inches

---

## Ethernet Management Port (EMP)

The Ethernet 10/100BaseT port located on the CMM's front panel provides out-of-band network management and can be used for Telnet sessions, switch diagnostics, and for downloading switch software via FTP. The 10/100BaseT port supports both 10BaseT and 100BaseT with auto-negotiation through the RJ-45 connector.

---

**Note.** In redundant CMM configurations, the EMP is only operational on the *primary* CMM. You must have a valid Ethernet connection to the EMP on the primary CMM before establishing an EMP connection with the switch. For more information on redundant CMM configurations, refer to [page 3-10](#).

---

### Modifying the EMP Port IP Address

If you wish to modify the default EMP IP address settings, refer to the following steps:

- 1 Enter **modify boot parameters** at the CLI prompt. The boot prompt displays:

```
Boot >
```

- 2 To change the IP address modify the **empipaddr** parameter. For example:

```
Boot > boot empipaddr 10.11.100.1
```

- 3 To change the net mask modify the **empnetmask** parameter and enter the value in hexadecimal format. For example to change the netmask to 255.255.255.0 enter the following:

```
Boot > boot empnetmask ffffff00.
```

- 4 To change the gateway address modify the **boot empgatewayipaddr** , parameter. For example:

```
Boot > boot empgatewayipaddr 10.11.100.253
```

**5** Verify your current changes by entering **show** at the boot prompt:

```

Boot > show
Edit buffer contents:
EMP IP Address       : 10.11.100.1
EMP Gateway IP Address : 10.11.100.253

```

*(additional table output not shown)*

**6** You can save your changes to the **boot.params** file by entering **commit file** at the boot prompt:

```

Boot > commit file

```

---

**Note.** When the **commit file** command is used, changes will not be enabled until after the next switch reboot.

---

**7** You can also save your changes in real time to the switch's running memory by entering **commit system** at the boot prompt:

```

Boot > commit system

```

---

**Caution.** There are two important things to consider when using the **commit system** command to save EMP changes:

- All existing IP sessions will be disconnected.
  - If you use the **commit system** command only, changes will *not* be saved to the switch's **boot.params** file and will be lost if the switch is rebooted. To save changes to the **boot.params** file, refer to step 5.
- 

**8** Return to the CLI prompt by entering **exit** at the boot prompt.

## Routed Access to the EMP

By default, only devices in the same subnet as the EMP will be able to manage the switch through that port. To allow access to the EMP to devices outside the EMP's local network, you can create a static route between the EMP and the network containing devices requiring access to the EMP.

To create a static route for the EMP, use the **ip static-route** command. The command syntax must include the network IP address as well as the gateway address for the EMP. For example:

```

-> ip static-route 10.11.100.1 gateway 10.11.100.253

```

## EMP Cable Requirements

There are specific cable type requirements (i.e., straight-through or crossover) based on the type of device to which the EMP is connecting. Refer to the information below:

<b>EMP to a Switch</b>	Straight-through
<b>EMP to a Computer or Workstation</b>	Crossover



## Console Port

### Serial Connection to the Console Port

The console port, located on the CMM front panel, provides a serial connection to the switch and is required when logging into the switch for the first time. By default, this R-J45 connector provides a DCE console connection.

#### Serial Connection Default Settings

The factory default settings for the serial connection are as follows:

<b>baud rate</b>	9600
<b>parity</b>	none
<b>data bits (word size)</b>	8
<b>stop bits</b>	1
<b>X-ON/X-OFF</b>	enabled

#### Modifying the Serial Connection Settings

If you wish to modify the default serial connection settings (i.e., baud rate, parity, data bits, and stop bits), refer to the following steps:

---

**Note.** You must be connected to the switch via the console port before attempting to change the serial connection settings. Otherwise, an error message will display.

---

- 1 Enter **modify boot parameters** at the CLI prompt. The boot prompt displays:

```
Boot >
```

- 2 To change the baud rate, enter **boot serialbaudrate**, followed by the desired baud rate value. Options include 1200, 2400, 4800, 9600 (default), 19200, 38400, 57600, 76800, and 115200. For example:

```
Boot > boot serialbaudrate 19200
```

---

**Note.** Setting the console port to speeds above 9600 baud can cause problems with Zmodem uploads.

---

- 3 To change the parity value, enter **boot serialparity**, followed by the desired parity value. Options include none (default), even, and odd. For example:

```
Boot > boot serialparity even
```

- 4 To change the data bits (i.e., word size) value, enter **boot serialwordsize**, followed by the number of data bits. Options include 7 and 8 (default). For example:

```
Boot > boot serialwordsize 7
```

- 5 To change the stop bits value, enter **boot serialstopbits**, followed by the number of stop bits. Options include 1 (default) and 2. For example:

```
Boot > boot serialstopbits 2
```

- 6** Verify your current changes by entering **show** at the boot prompt:

```
Boot > show
Edit buffer contents:
Serial (console) baud           : 19200
Serial (console) parity        : even
Serial (console) stopbits      : 2
Serial (console) wordsize      : 7
```

*(additional table output not shown)*

- 7** You can save your changes to the **boot.params** file by entering **commit file** at the boot prompt:

```
Boot > commit file
```

---

**Note.** When the **commit file** command is used, changes will not be enabled until after the next switch reboot.

---

- 8** You can also save your changes in real time to the switch's running memory by entering **commit system** at the boot prompt:

```
Boot > commit system
```

---

**Caution.** There are two important things to consider when using the **commit system** command to save serial connection changes:

- Output to the terminal may become illegible due to incompatible serial connection settings between the switch and the terminal emulation software.
  - If you use the **commit system** command only, changes will *not* be saved to the switch's **boot.params** file and will be lost if the switch is rebooted. To save changes to the **boot.params** file, refer to step 7.
- 

- 9** Return to the CLI prompt by entering **exit** at the boot prompt.

## Configuring X-ON/X-OFF Protocol

By default, the X-ON/X-OFF protocol is enabled on the console port. To enable and disable the X-ON/X-OFF protocol on a console port that you are logged into use the **session xon-xoff** command by entering **session xon-xoff** followed by either **enable** or **disable**.

For example, to disable X-ON/X-OFF on a console port enter:

```
-> session xon-xoff disable
```

---

**Note.** To enable or disable the X-ON/X-OFF protocol on the secondary CMM, you must log into the secondary CMM and then execute the **session xon-xoff** command.

---

# CMM Redundancy

CMM redundancy is one of the switch's most important failover features. For CMM redundancy, two fully-operational CMM modules must be installed in the chassis at all times. In addition, the software on the two CMM modules must be synchronized. (Refer to “[Synchronizing the Primary and Secondary CMMs](#)” on page 3-11 for more information.)

When two CMMs are running in the switch, one CMM has the primary role and the other has the secondary role at any given time. The primary CMM manages the current switch operations while the secondary CMM provides backup (also referred to as “failover”).

In a redundant configuration, if the primary CMM fails or goes offline for any reason, the secondary CMM is instantly notified. The secondary CMM automatically assumes the primary role.

## CMM Failover Sequence

The figure below illustrates the CMM failover sequence:

- 1 CMM A (installed in the left-hand Slot A position) is operating in the primary mode. CMM B (installed in the right-hand Slot B position) is operating in the secondary mode—i.e., it is functioning as the standby CMM and is ready to take over chassis management functions in the event of a primary CMM failure.
- 2 CMM A fails or is taken offline (e.g., the module is physically removed from the chassis).
- 3 CMM B automatically assumes the primary role.

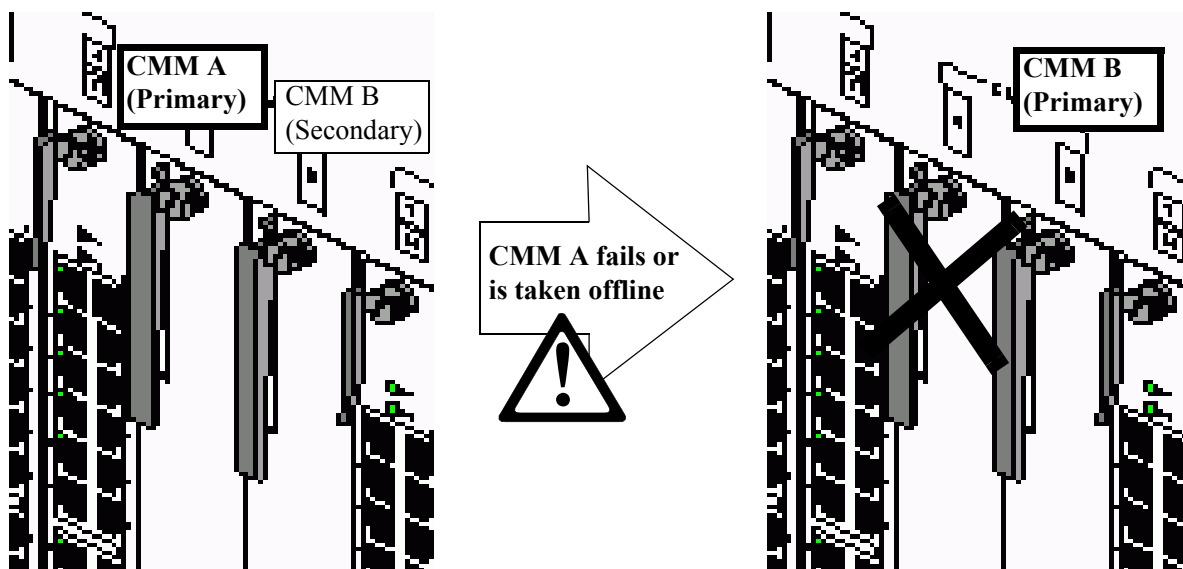

Redundant CMM Failover

---

**Ethernet Management Ports (EMPs) and Redundancy.** In redundant CMM configurations, the Ethernet Management Port (EMP) is only operational on the *primary* CMM. For additional information on the EMP, refer to [page 3-5](#).

---

## Synchronizing the Primary and Secondary CMMs

CMM synchronization refers to the process of copying all files in the **/flash/working** and **/flash/certified** directories of the primary CMM to the **/flash/working** and **/flash/certified** directories of the secondary CMM. This ensures that these directories match exactly on both modules, which prevents the secondary CMM from assuming the primary role with incorrect or outdated software or configuration files in the event of a primary CMM failure.

---

**Important.** In order to have effective CMM redundancy, CMM modules must be synchronized at all times.

---

To synchronize the primary and secondary CMM modules, enter the following command at the CLI prompt:

```
-> copy flash-synchro
```

For more information on CMM synchronization and managing the **/flash/working** and **/flash/certified** directories, refer to the “Managing CMM Directory Content” chapter in the *Switch Management Guide*.

## CMM Switching Fabric

Each CMM module contains hardware and software elements to provide management functions for the OS9000E system. The OS9000E CMM module also contains the switch fabric for the OS9000E system. User data flowing from one NI module to another passes through the switch fabric.

The OS9000E will operate with one or two CMM modules installed.

If there are two CMM modules, one management processor is considered “primary” and is actively managing the system. The other management processor is considered “secondary” and remains ready to quickly take over management in the event of hardware or software failure on the primary. In the event of a failure, the two processors exchange roles and the secondary takes over as primary.

The switch fabric on the CMM operates independently of the management processor. If there are two CMM modules installed, both fabric modules are normally active. Two CMM modules must be installed in the OS9000E to provide full fabric capacity.

If there is one CMM module installed, then there is a single management feature and performance as a dual CMM system, but there is no “secondary” CMM. Hardware or software failures in the CMM will result in a system reboot. The System fabric capacity is on half of the fabric capacity of a dual CMM system.

# Hot Swapping CMM Modules

Hot swapping a CMM refers to the action of adding, removing, or replacing a CMM module while the switch is operating. You are not required to enter a CLI command in order to hot swap CMM modules. This function can be performed on the fly by simply removing the module from the switch chassis.

## Module Presence Signalling

On-the-fly module removal is provided through the presence signalling function. All modules in the switch send out “presence signals.” When a module sends out this signal, it is essentially advertising to all other modules in the switch that it is present in the chassis. When a module is present, information such as its module type (primary CMM, secondary CMM, GNI, or XNI) becomes available for monitoring functions.

The presence signal is controlled through a shortened connector pin that interfaces with the switch’s backplane. Because this connector pin is shorter than the module’s other backplane connectors, the presence signal connection is the first to become interrupted when a board is removed from the chassis. This allows the switch additional time (approximately 5 ms) to complete the current transfer of data before the module is completely disconnected. (In order to avoid data loss, the switch immediately stops incoming traffic and flushes outgoing traffic on the module being removed.)

---

**Note.** Although presence signalling is designed to maintain data flow on the switch during the hot swap procedure, uninterrupted data flow cannot be guaranteed. As a result, you should not hot swap CMM modules during critical network activity.

---

## Hot Swap Requirements

---

**Important.** There are important conditions that must be met before a CMM can be hot swapped. Be sure to read the information below before attempting to hot swap a CMM module.

---

### Removing or Replacing CMMs

You must have CMM redundancy before removing or replacing a CMM. If the switch has only one CMM installed and you attempt to hot swap the module, all switch management functions as well as network data flow will be terminated. For important information on CMM redundancy, refer to [page 3-10](#).

Also, before removing or replacing the primary CMM in a redundant configuration, verify that the primary and secondary CMM modules are synchronized. Otherwise, data flow and switch management functions may be interrupted due to incorrect or outdated software when the secondary CMM takes over. For more information, refer to [“Synchronizing the Primary and Secondary CMMs” on page 3-11](#).

## **Adding a Secondary CMM**

A secondary (or *redundant*) CMM module can be added to the chassis at any time without disturbing the operation of the switch. However, you should synchronize the primary and secondary CMMs immediately after the hot swap in order to have effective redundancy. For more information, refer to [“Synchronizing the Primary and Secondary CMMs” on page 3-11](#).

---

**Note.** For detailed instructions on physically installing and removing modules (both NIs and CMMs), refer to [Chapter 4, “Network Interface \(NI\) Modules.”](#)

---

# Managing CMM Modules

Refer to the “Managing CMM Directory Content” chapter in the *Switch Management Guide* for detailed information on managing CMM modules.

## Reloading a CMM Module

You can reload either the primary or secondary CMM module using the CLI’s **reload** command. For information on using this command, refer to the “Managing CMM Directory Content” chapter in the *Switch Management Guide*. A CMM reload is essentially a soft boot of the module. Note that you can reload only one CMM module at a time; the primary and secondary CMMs cannot be reloaded simultaneously.

### Reloading the Primary CMM

If the primary CMM is reloaded, the secondary CMM automatically takes over primary management functions. In other words, the secondary CMM becomes the primary CMM as soon as the reload is initiated. The reloaded CMM then assumes the secondary—or *redundant*—role when the reload sequence is complete.

### Reloading the Secondary CMM

If the secondary CMM is reloaded, only the secondary CMM is affected. The primary CMM continues all operations without interruption.

## Switching the Primary and Secondary Roles

The primary and secondary CMM modules can trade roles. In other words, the CMM that is currently functioning as the secondary CMM can be assigned to “take over” the role of the primary CMM. The primary CMM then assumes the secondary role. Because this action is coordinated between the two CMM modules, switch management functions are maintained during the takeover.

To manually designate the secondary CMM to assume the primary role, enter the **takeover** command at the CLI prompt. For example:

```
-> takeover
```

You can also use the **show running-directory** command to display whether the CMM you are currently logged in to is primary or secondary. For example:

```
Current running CMM           : PRIMARY,  
Current running configuration : WORKING,  
Certify/Restore Status       : CERTIFIED,  
Synchronization Status      : SYNCHRONIZED
```

In this example, the user is currently logged in to the primary CMM.

---

**Note.** Before using the **takeover** command, verify that the primary and secondary CMM modules are synchronized. Otherwise, data flow and switch management functions may be interrupted due to incorrect or outdated software when the secondary CMM takes over. For more information, refer to [“Synchronizing the Primary and Secondary CMMs” on page 3-11](#).

---



# Monitoring CMM Modules

## Front Panel LEDs

The CMM provides a series of status LEDs on the module's front panel. These LEDs offer basic status information for the following switch functions:

- CMM hardware operation (OK1)
- System software (OK2)
- CMM processor status (CONTROL)
- CMM fabric status (FABRIC)
- Chassis ambient air temperature (TEMP)
- Fan status (FAN)
- Power Supply Unit (PSU) status (PSU)
- Ethernet management port (LINK and ACT)

Refer to [page 3-3](#) for detailed information on CMM front panel LEDs.

## Accessing General CMM Information

The switch's Command Line Interface (CLI) offers CMM monitoring commands. These commands allow you to access general CMM hardware information as well as the current operating status of CMM-related components.

### CMM Hardware Information

The [show cmm](#) and [show hardware info](#) commands are used to display general hardware information for the CMM module(s) installed in the chassis.

Use the **show cmm** command to display the following information:

- Model name and description for each CMM
- Part number and serial number
- Hardware revision level
- Manufacture date
- Firmware version number
- Administrative and operating status
- Additional information, such as power control checksum, ASIC information, and chassis MAC Address (see [page 3-18](#) for information on MAC address storage)

For a detailed information on the **show cmm** command, including output table descriptions, refer to the *OmniSwitch CLI Reference Guide*.

The **show hardware info** command displays the following information:

- CPU type
- Flash manufacturer and flash size
- RAM manufacturer and RAM size
- NVRAM battery status
- Jumper settings
- BootROM and Miniboot versions
- FPGA version(s)

For detailed information on the **show hardware info** command, including output table descriptions, refer to the *OmniSwitch CLI Reference Guide*.

## Operating Status of CMM-Related Components

The CMM contains the switch's temperature sensor and monitors fan operation. If the TEMP or FAN LEDs on the CMM's front panel indicate an error, you can use the **show temperature** and **show fan** commands to access additional status information.

For information on reading temperature and fan status LEDs, refer to [page 3-3](#).

For information on using the **show temperature** and **show fan** commands, as well as information on temperature management and fan maintenance, refer to [Chapter 2, "Chassis and Power Supplies."](#)

## CLI Commands Supported on Both the Primary and Secondary CMMs

Although most CLI commands are executed when logged into the primary CMM, there is a group of commands that is supported when logged in to either the primary or secondary CMM. For a list of these commands, refer to the tables below. The tables are grouped by chapter according to the *OmniSwitch CLI Reference Guide*.

CMM Commands		
<b>reload</b>	<b>debug chassis auto-reboot</b>	<b>show reload</b>
<b>takeover</b>	<b>show running-directory</b>	<b>show microcode</b>
<b>install</b>		

Chassis Management and Monitoring Commands		
<b>show system</b>	<b>show cmm</b>	<b>show module long</b>
<b>show hardware info</b>	<b>show ni</b>	<b>show module status</b>
<b>show chassis</b>	<b>show module</b>	

---

**File Management Commands**

---

cd	delete	ed
pwd	cp	vi
mkdir	mv	view
rmdir	move	tty
ls	chmod	show tty
dir	attrib	rz
rename	fsck	more
rm	newfs	install

---

---

**Switch Logging and Monitoring Commands**

---

swlog	debug ktrace	debug systrace show
swlog appid level	debug ktrace appid level	debug systrace show log
swlog output	debug ktrace show	debug memory monitor
show log swlog	debug systrace	debug memory monitor show log
show swlog	debug systrace appid level	

---

---

**Memory Monitoring Commands**

---

show log pmd

---

---

**Session Management Commands**

---

session timeout

---

## Chassis-Based MAC Address

The switch's base MAC address is not tied to the CMM module. Instead, the switch provides an EEPROM card near the chassis backplane that stores the MAC address. This allows the switch to retain the MAC address when a CMM module is removed or replaced. For detailed information on MAC address management on the switch, refer to the "Managing MAC Addresses and Ranges" chapter in the *Switch Management Guide*.

---

**MAC EEPROM Redundancy.** A second EEPROM is provided for redundancy. An EEPROM card can be removed and replaced in the field by an authorized Alcatel-Lucent Support Engineer in the unlikely event of an EEPROM failure.

---

## Pinouts

### RJ-45 Console Port – Connector Pinout

Pin Number	Signals as DTE Console Port
1	NC
2	NC
3	RXD
4	Ground
5	Ground
6	TXD
7	NC
8	NC

# 4 Network Interface (NI) Modules

Several Gigabit Network Interface (GNI) and 10-gigabit Network Interface (XNI) modules are currently available for OmniSwitch 9000E Series switches. These modules come in a variety of port speeds, including auto-sensing 10/100/1000 Mbps Ethernet, Gigabit Ethernet (1 Gbps), and 10-gigabit Ethernet (10 Gbps). In addition, these modules come with several connector types, including copper RJ-45 connectors on 10/100/1000 modules and LC connectors on fiber Gigabit Ethernet and 10-gigabit Ethernet modules.

## In This Chapter

This chapter provides specifications and descriptions of all GNI and XNI modules currently available for OmniSwitch 9000E Series switches. In addition, procedures using Command Line Interface (CLI) commands to manage and monitor GNI and XNI modules are also provided.

---

**Note.** OmniSwitch 9000E NIs are colored with a purple stripe to distinguish them from OmniSwitch 7700/7800/9700/9800 NIs that are colored white and orange. Do *not* install OmniSwitch 9000E and OmniSwitch 7700/7800/9700/9800 NIs in the same chassis.

---

Specifications, descriptions, and procedures in this chapter include:

- Specifications and descriptions of GNI modules on [page 4-3](#).
- Specifications and descriptions of XNI modules on [page 4-8](#).
- An overview of smart continuous switching on [page 4-11](#).
- Procedures for managing NI modules on [page 4-11](#).
- Procedures for monitoring NI modules on [page 4-12](#).
- An overview of hot swapping on [page 4-13](#).
- Procedures for adding and removing Chassis Management Modules (CMMs) and NI modules on [page 4-14](#).

- Pinouts of RJ-45 ports on 10/100/1000 modules on [page 4-19](#).
- An overview of proper handling of fiber optic cables on [page 4-20](#).

---

**Note.** You can also manage and monitor GNI and XNI modules with WebView, Alcatel-Lucent's embedded web-based device management application. WebView is an interactive and easy-to-use GUI that can be launched from OmniVista or a Web browser. Please refer to WebView's online documentation for more information.

---

## GNI Modules

Gigabit Ethernet Network Interface (GNI) modules provide 1000 Mbps (1 Gbps) connections. GNI modules can be used for backbone connections in networks where Gigabit Ethernet is used as the backbone media. GNI modules can also be used in the wiring closet.

The following GNI modules are available:

- **OS9-GNI-C24E.** Provides 24 auto-sensing twisted-pair ports, individually configurable as 10BaseT, 100BaseTX, or 1000BaseT. Refer to [page 4-4](#) for detailed information on this module.
- **OS9-GNI-U24E.** Provides 24 SFP connectors. Refer to [page 4-6](#) for detailed information on this module.

SFPs, also known as Small Form Factor Pluggable transceivers (SFPs) are Gigabit Ethernet port modules that are hot-pluggable—i.e., they can be installed or removed while the GNI is powered on and operating without the risk of damage to the SFP transceiver module or the host circuitry.

GNI modules are also supported during CMM failover. Refer to [“Smart Continuous Switching” on page 4-11](#) for details.

See [“Handling Fiber and Fiber Optic Connectors” on page 4-20](#) for proper handling of LC connectors and fiber-optic cable.

## OS9-GNI-C24E Front Panel

### Module Status LEDs

**OK1.** Hardware Status. Displays solid green when powered on and the GNI has passed hardware diagnostic tests. Displays solid amber when powered on and the GNI has failed hardware diagnostic tests.

**OK2.** Software Status. Blinks green when the GNI is operational and has successfully loaded software. Displays solid amber when powered on and the GNI has failed to load software.

### Ethernet Port LEDs

Each fiber-based Ethernet port has a corresponding LED. This LED indicates the link and the activity status for each Ethernet port. The LED displays green when a valid Ethernet cable connections exists. Flashes green as data is transmitted or received on the port.

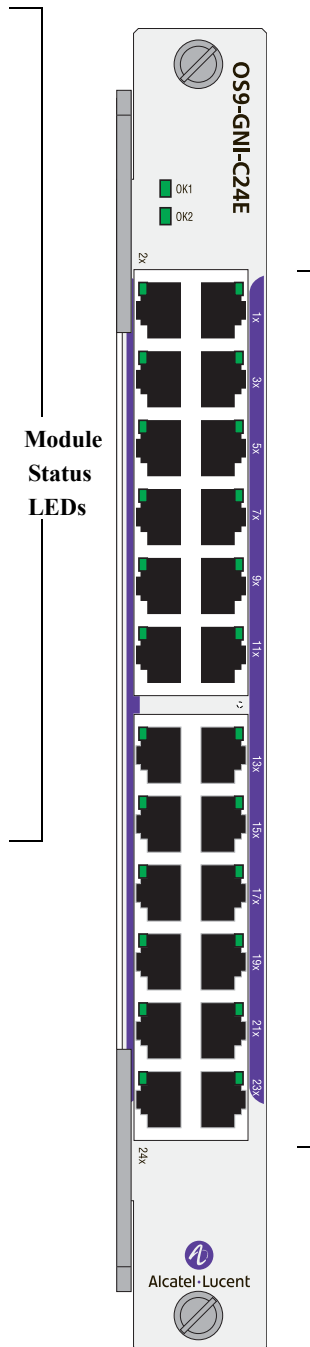

Module  
Status  
LEDs

### Ethernet Ports

The OS9-GNI-C24E module provide 24 10/100/1000 Ethernet ports. These ports are twisted-pair and are individually configurable as 10BaseT, 100BaseTX, or 1000BaseT. The ports use RJ-45 connectors.

Refer to the Technical Specifications table on [page 4-5](#) for more information.

OS9-GNI-C24E Front Panel



**OS9-GNI-C24E Technical Specifications**

Number of ports	24 twisted-pair
Connector type	RJ-45
Standards supported	802.3z, 802.3ab; 1000Base-T
Data rate	10 or 100 Mbps (full or half duplex) 1 Gbps (full duplex)
Maximum frame size	1536 bytes(10 or 100 Mbps) 9216 bytes(1 Gigabit) OS9-GNI-C24E modules support jumbo frames (1500 to 9000E bytes)
MAC addresses supported	16000 per Network Interface (NI) module
Connections supported	10 Mbps - 10BaseT hub or device 100 Mbps - 100BaseTX hub or device 1 Gbps - 1000BaseT connection to backbone or server
Cables supported	10 Mbps - 10BaseT: unshielded twisted-pair (UTP) 100 Mbps - 100BaseTX: unshielded twisted-pair (UTP), Category 5, EIA/TIA 568 or shielded twisted-pair (STP), Category 5, 100 ohm 1 Gbps - 1000BaseT: unshielded twisted-pair (UTP), Category 5e
Maximum cable distance	100 meters, Category 5, 5e, 6
Power	51 W
Width	9.875 inches
Height	1.25 inches
Depth	13.024 inches

## OS9-GNI-U24E Front Panel

### Module Status LEDs

**OK1.** Hardware Status. Displays solid green when powered on and the GNI has passed hardware diagnostic tests. Displays solid amber when powered on and the GNI has failed hardware diagnostic tests.

**OK2.** Software Status. Blinks green when the GNI is operational and has successfully loaded software. Displays solid amber when powered on and the GNI has failed to load software.

### Gigabit Ethernet Port LEDs

Each fiber-based Ethernet port has a corresponding LED. This LED indicates the link and activity status for each Ethernet port. The LED displays green when a valid Ethernet cable connection exists. It flashes green as data is transmitted or received on the port.

### Module Status LEDs

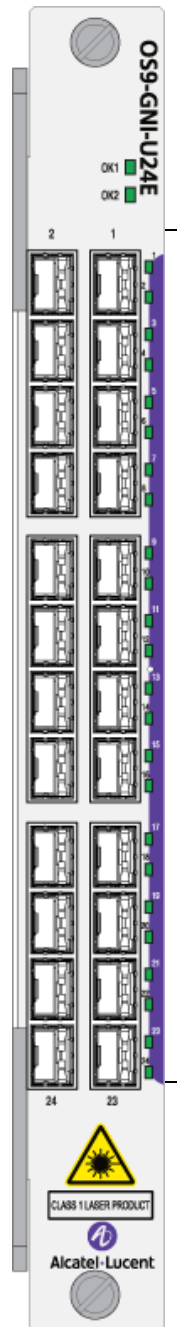

### Gigabit Ethernet Ports

The OS9-GNI-U24E module provides 24 SFP connectors.

## OS9-GNI-U24E Front Panel

---

**OS9-GNI-U24E Technical Specifications**

---

Number of SFP transceiver ports	24 (hot-pluggable)
Standards supported	802.3z; 1000Base-SX, 1000Base-LX
Maximum frame size	9216 bytes OS9-GNI-U24E modules support jumbo frames (1500 to 9000E bytes)
MAC addresses supported	16000 per Network Interface (NI) module
Fiber optical Cables supported	Single mode and multimode
Power	55 W
Width	9.875 inches
Height	1.25 inches
Depth	13.024 inches

---

Note: For a technical breakdown of each SFP transceiver type, standards, connections and distances, refer to the *OmniSwitch Transceivers Guide*.

---

## XNI Modules

OmniSwitch 9000E 10-gigabit Network Interface (XNI) modules provide up to two 10000 Mbps (10 Gbps) connections per module. In addition, XNI modules can be used in enterprise applications including backbone connections in networks where 10-gigabit Ethernet is used as the backbone media.

Like GNI modules, XNI modules are also supported during CMM failover. Refer to [“Smart Continuous Switching” on page 4-11](#) for details.

See [“Handling Fiber and Fiber Optic Connectors” on page 4-20](#) for proper handling of LC connectors and fiber-optic cable.

The following wire-rate 10 Gbps XNI modules are available:

- **OS9-XNI-U2E.** Provides two XFP connectors. Refer to [page 4-9](#) for detailed information on this module.

## OS9-XNI-U2E Front Panel

### Module Status LEDs

**OK1.** Hardware Status. Displays solid green when powered on and the XNI has passed hardware diagnostic tests. Displays solid amber when powered on and the XNI has failed hardware diagnostic tests.

**OK2.** Software Status. Blinks green when the XNI is operational and has successfully loaded software. Displays solid amber when powered on and the XNI has failed to load software.

### LINK/ACT LED

Each 10-gigabit port has a single LED for monitoring XFP link status and activity. The LED displays solid green when the port is up; the LED blinks green when it is transmitting or receiving packets in a link up state. The LED is off when no link is detected.

### Module Status LEDs

### 10-gigabit Ethernet Ports

The OS9-XNI-U2E module provides 2 XFP connectors.

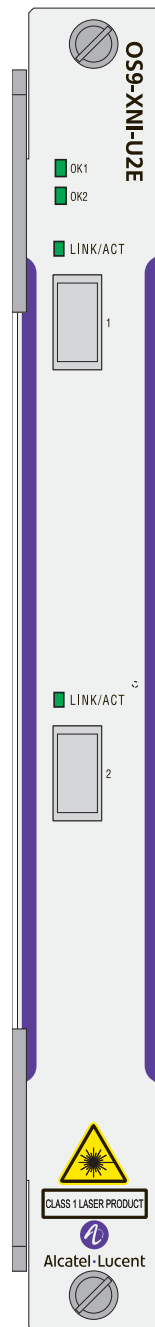

## OS9-XNI-U2E Front Panel

---

**OS9-XNI-U2E Technical Specifications**

---

Number of XFP connectors	2
Connector types	LC
Standards supported	IEEE 802.3ae 10-gigabit Ethernet
Data rate	10 gigabit per second (full duplex)
Maximum frame size	9212 bytes
MAC addresses supported	16000 per Network Interface (NI) module
Power	55 W
Width	9.875 inches
Height	1.25 inches
Depth	13.024 inches

---

Note: For a technical breakdown of each XFP transceiver type, standards, connections and distances, refer to the *OmniSwitch Transceivers Guide*.

---

# Smart Continuous Switching

In redundant CMM configurations, the switch provides support for NIs during failover. In other words, if the primary CMM fails or goes offline for any reason, NI modules will continue data transmission and routing functions during the secondary CMM's takeover process. This Availability feature is referred to as *Smart Continuous Switching*.

Incoming Layer 2 packets will continue to be sent to the appropriate egress port during failover. The known routes will also be supported. (Note, however, that the NI cannot learn new routes without CMM support. Any new route information will be ignored.) Spanning Tree will continue handling BPDUs received on the switch ports, as well as port link up and down states. The Spanning Tree topology will not be disrupted.

---

**Note.** Smart Continuous Switching is designed to maintain traffic flow only during CMM failover and is *not* intended to support long-term traffic flow. If both the primary and redundant CMM modules go offline or are removed from the chassis, switch operations (including all NI support) will be disabled.

---

## Module Priorities During Boot Sequence

During the power checking sequence, CMMs receive priority and are always powered on. NI modules are then powered on sequentially by slot position. In other words, the NI in slot 1 is powered on, then slot 2, then slot 3, etc. For information on slot positions, refer to [Chapter 2, “Chassis and Power Supplies.”](#)

# Managing NI Modules

## Turning Power On or Off for a Specific NI Module

The CLI allows you to power on or power off specific NI modules. To turn the power off for a specific NI module, use the **no** form of the [temp-threshold](#) command. Be sure to specify the syntax **no**, along with the slot number of the NI. For example:

```
-> no power ni slot 3
```

To return power to a specific NI module, use the **power ni** command. Be sure to specify the slot number of the NI in the command line. For example:

```
-> power ni slot 3
```

## Individual NI Reload

Each NI installed in the switch can be reloaded on an individual basis. A reload is essentially a soft boot of the NI module. When an individual NI is reloaded, only the specified NI is affected. All other NIs installed in the switch continue operating without interruption. To reload a specific NI module, use the [reload ni](#) command. Be sure to specify the slot number of the NI in the command line. For example:

```
-> reload ni 3
```

For detailed information on the **no power ni**, **power ni**, and **reload ni** commands, refer to the “Chassis Management and Monitoring Commands” chapter in the *OmniSwitch CLI Reference Guide*.

# Monitoring NI Modules

## Front Panel LEDs

All NIs provide a series of status LEDs located on the front panel. These LEDs offer basic status information for the following functions:

- NI hardware operation
- NI software status
- Port link and activity status

## Accessing General NI Information

The switch's Command Line Interface (CLI) offers NI monitoring commands. These commands allow you to access general NI hardware information as well as the current operating status.

To access general NI information, use the `show ni` command. For example:

```
-> show ni 6
Module in slot 6
  Model Name:          OS9-GNI-U24E,
  Description:        24PT FIB GIG MOD,
  Part Number:        902073-10,
  Hardware Revision:  B13,
  Serial Number:      3056018A,
  Manufacture Date:   MAR 05 2005,
  Firmware Version:   6,
  Admin Status:       POWER ON,
  Operational Status: UP,
  Power Consumption:  100,
  Power Control Checksum: 0x88d,
  MAC Address:        00:d0:95:8a:09:b8,
  ASIC - Physical 1 (hex): 1a01 1a01 1a01 1a01 0101 0101 0101 0101
```

For more information about this display and other NI monitoring commands, see the “Chassis Management and Monitoring Commands” chapter in the *OmniSwitch CLI Reference Guide*.



# Hot Swapping NI Modules

You are not required to enter a CLI command in order to hot swap NI modules. The hot swap function can be performed on the fly by simply removing the module from the switch chassis. For information on properly removing modules, refer to [“Removing a Module” on page 4-15](#).

## Module Presence Signalling

On-the-fly module removal is provided through the presence signalling function. All modules in the switch send out “presence signals.” When a module sends out this signal, it is essentially advertising to all other modules in the switch that it is present in the chassis. When a module is present, information such as its module type (primary CMM, secondary CMM, GNI, or XNI) becomes available for monitoring functions.

The presence signal is controlled through a shortened connector pin that interfaces with the switch’s backplane. Because this connector pin is shorter than the module’s other backplane connectors, the presence signal connection is the first to become interrupted when a board is removed from the chassis. This allows the switch additional time (approximately 5 ms) to complete the current transfer of data before the module is completely disconnected. (In order to avoid data loss, the switch immediately stops incoming traffic and flushes outgoing traffic on the module being removed.)

---

**Note.** Although presence signalling is designed to maintain data flow on the switch during the hot swap procedure, uninterrupted data flow cannot be guaranteed. As a result, you should not hot swap NI or CMM modules during critical network activity.

---

# Removing and Adding Modules

## Using the Grounding Wrist Strap and Chassis Grounding Lug

As electrostatic discharge (ESD) can damage switch components such as the Network Interface (NI) and Chassis Management Modules, you must always ground yourself properly before removing or adding a module. For this purpose, Alcatel-Lucent provides a grounding wrist strap and a grounding lug located near the bottom-right of the chassis. To properly ground yourself, follow the steps below:

- 1 Fasten the grounding strap to your wrist. (A grounding strap was provided in your OmniSwitch 9000E ship kit.)
- 2 Insert the wrist strap's connector pin (located at the end of the strap's tether) into the grounding lug near the bottom-right of the chassis, as shown.

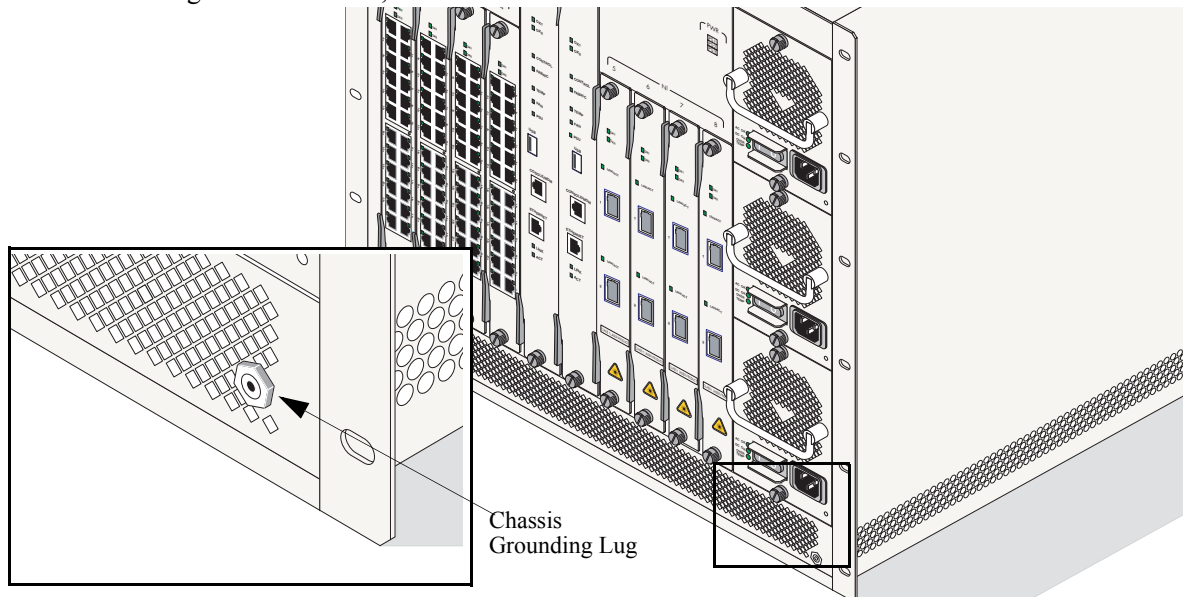

---

**Important.** For the grounding wrist strap to be effective in eliminating ESD, power supplies must be installed in the chassis and plugged into grounded AC outlets.

---

## Module Types and Slot Positions

When installing modules in the chassis, consider the following:

- NI modules may be installed in any slot position from 1 through 16 in OS9800E switches and from 1 through 8 in OS9700E switches.
- CMMs may be installed in slots A or B.
- NI modules cannot be installed in CMM slots A or B; likewise, CMMs cannot be installed in any NI slot position.

---

**More Information on Slot Numbering.** For a diagram showing the chassis layout and slot positions, refer to [Chapter 2, “Chassis and Power Supplies.”](#)

---

## Removing a Module

To remove an NI or CMM module from the chassis, follow the steps below.

- 1 First, loosen the module's two captive screws that secure the module to the chassis. If necessary, use a flat-blade screwdriver to loosen the screws. Be sure that both captive screws are completely disengaged from the threaded holes in the chassis before continuing.

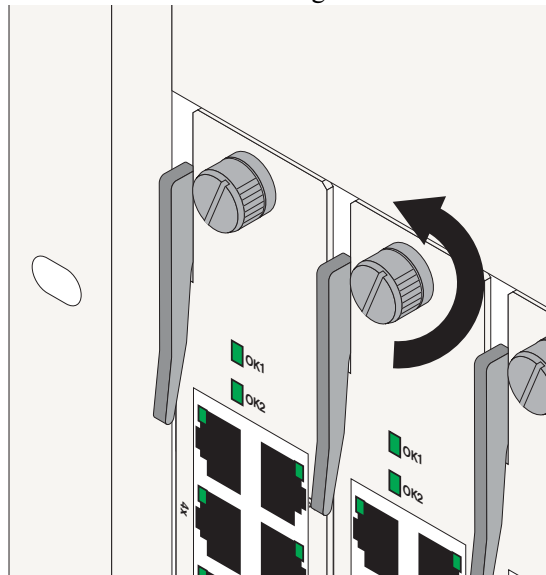

**2** Next, simultaneously pull the two module extractor levers—one on top of the module and one on the bottom—until the module disengages from the chassis.

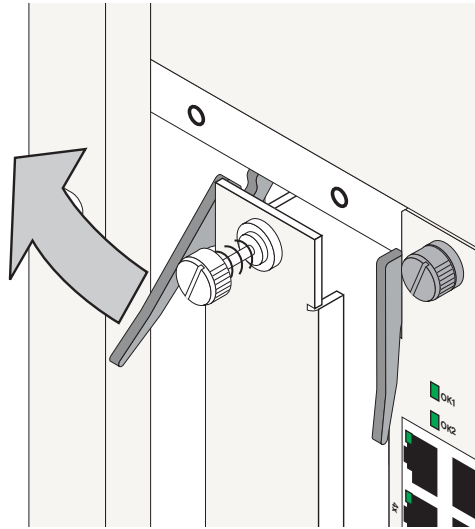

**3** Holding the module in both hands, carefully slide it out of the chassis along the card guide. The module should slide out easily. Do not force the module from the slot.

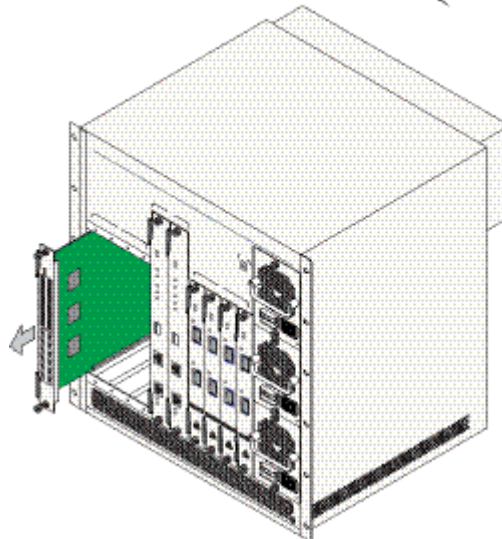

## Adding a Module

To install an NI or CMM module, follow the steps below:

---

**Important.** Before beginning, note that the CMM modules and NI modules slide into the chassis card guides differently. CMMs have a sheet metal tray that slides into the guides; with NIs, the edges of the module's printed circuit slide into the guides.

---

- 1 Holding the module in both hands, carefully slide it into the chassis card guide. The component side of the board should face right.

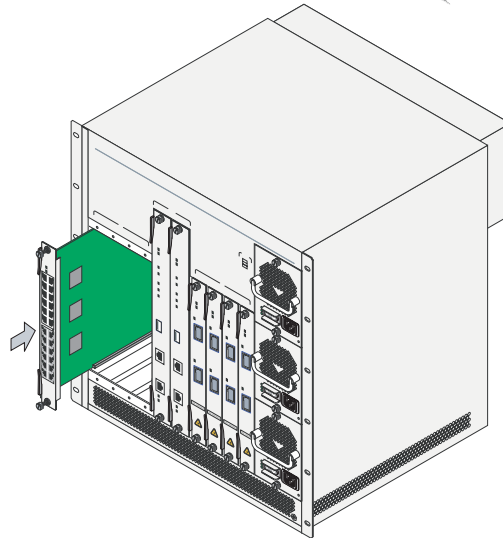

- 2 The module should slide in easily. Do not force the module into the slot. If any resistance is encountered, ensure the module is aligned properly in the card guide. Also, see the important note regarding chassis card guides on [page 4-17](#).
- 3 When the module is nearly seated in the slot, be sure that the two extractor levers—one on top of the module and one on the bottom—are slightly opened (approximately 30 degrees). This allows the notch on each extractor lever to grasp the rail on the chassis. Once the notches have grasped the rail, press both extractor levers inward simultaneously until the module is firmly seated.

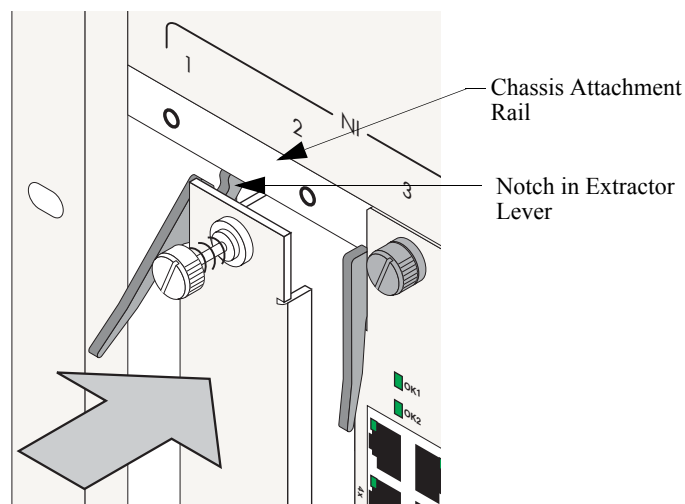

**4** Once the module is firmly seated, secure the module to the chassis by tightening the two captive screws. *Be sure not to overtighten the captive screws. If you use a screwdriver, the torque used to tighten the screws must not exceed 2.3 foot-pounds.*

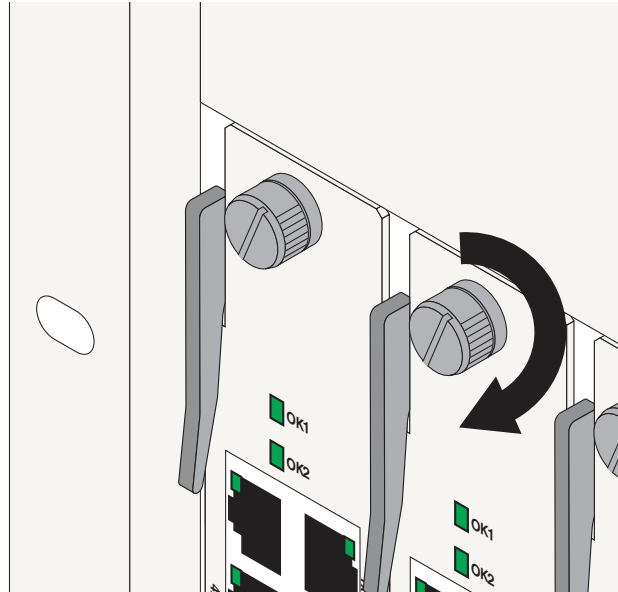

# Pinouts

## 10/100 Mbps Ethernet Port – RJ-45 Pinout

Pin Number	Description
1	RX+
2	RX-
3	TX+
4	not used
5	not used
6	TX-
7	not used
8	not used

## 1 Gigabit Ethernet Port – RJ-45 Pinout

Pin Number	Description
1	BI_DB+
2	BI_DB-
3	BI_DA+
4	BI_DD+
5	BI_DD-
6	BI_DA-
7	BI_DC+
8	BI_DC-

# Handling Fiber and Fiber Optic Connectors

Using fiber is extremely simple, but several important standards should always be practiced. For best results, you should:

- Use premium grade jumper cables with duplex LC connectors
- Keep your fiber optic connectors clean
- Keep the transceiver interface clean
- Attenuate properly

For detailed information on these recommendations, refer to the sections below:

## Use Premium Grade Jumper Cables with Duplex LC Connectors

There are many brands of fiber optic jumper cables, with a wide range of quality between each manufacturer. Premium cables do three things well:

- They provide a good polish on the fiber optic connector endface (where the light exits the cable). Endface geometries must be exceptionally precise and aligned to extremely tight tolerances. The better the endface geometry, the lower the loss and more consistent the connection. Poor connector interfaces will reflect light back into the laser, causing an increase in laser noise.
- They mate well with other connector interfaces. Chances are the manufacturer of the jumper cable will not be the same as the manufacturer of the transceiver connector interface. Premium jumper cables mechanically align themselves well into most transceiver interfaces. This provides both better performance as well as better repeatability. You will always see a variance in transceiver power due to connector alignment, often as much as 0.3 to 0.7 dB. Good jumper cables help reduce this variance.
- They continue to mate well after many insertions and removals. Premium grade jumper use premium connectors that maintain their mechanical integrity up to and beyond 2000 insertion cycles.

For better repeatability, always use duplex (two connectors fused together and terminated to two cables) LC connectors on your jumper cables when connecting to a fiber-optic transceiver. Two simplex connectors inserted into a transceiver interface will often have up to 3 dB greater variation in repeatability compared to duplex connectors.

Never bend the fiber optic cable beyond its recommended minimum bend radius. This introduces bend losses and reflections that will degrade the performance of your system. It can also damage the fiber, although fiber is much tougher than most would assume. Still, it is highly recommended to buy only jumper cables with 3mm Kevlar jacketing, which offer superior protection and longer life.

## Keep Your Fiber Optic Connectors Clean

Unlike electrical connectors, fiber-optic connectors must be extremely clean in order to ensure optimum system performance. Microscopic particles such as dust on the connector endface (i.e., where the light exits the connector) can degrade the performance of your system, often to the point of failure.

If you have low-power output from a fiber-optic transceiver or a fault signal from your equipment, begin the troubleshooting process by cleaning your fiber-optic connectors per manufacturer recommendations.



### **Keep the Transceiver Interface Clean**

If you have cleaned your connectors, but still experience low-power output from a fiber-optic transceiver or a fault signal from your equipment, you should clean the transceiver interface by blowing inert dusting gas inside the transceiver interface. This removes dust and other small particles that may block the optical path between the optics of the transceiver and the connector's endface.

### **Attenuate Properly**

Often, equipment using laser-based transceivers need to have the optical path attenuated when performing loop-back testing or testing between two pieces of equipment. Too much optical power launched into the receiver will cause saturation and result in system failure. If you are using single mode fiber and you do not know the power output of the laser, it is always best to use a 10 dB attenuator when testing. Using the wrong type of attenuator will introduce problems, most notably reflection of light back into the laser, often resulting in excess noise and causing system failure.

Inline attenuators eliminate the need for additional jumper cables and thus reduce the number of connection interfaces. This increases the integrity of the optical path resulting in a more accurate test.

---

**CAUTION** - Use of controls or adjustments or performance of procedures other than those specified herein may result in hazardous radiation exposure.

---



# A Regulatory Compliance and Safety Information

This appendix provides information on regulatory agency compliance and safety for the OmniSwitch 9000 Series.

## Declaration of Conformity: CE Mark

This equipment is in compliance with the essential requirements and other provisions of Directive 73/23/EEC and 89/336/EEC as amended by Directive 93/68/EEC.

**Français:** Ce matériel est conformément aux conditions essentielles et à d'autres dispositions de 73/23/EEC et de 89/336/EEC directifs comme modifié par Directive 93/68/EEC.

**Deutsch:** Konformitätserklärung: CE Kennzeichnung  
Diese Anlage ist gemäß den wesentlichen Anforderungen und anderen Bestimmungen richtungweisenden 73/23/EEC und des 89/336/EEC, wie von Directive 93/68/EEC geändert.

**Español:** Este directivo equipo está en conformidad con los requisitos esenciales y otras provisiones 73/23/EEC y 89/336/EEC según la enmienda prevista por Directive 93/68/EEC.

## Waste Electrical and Electronic Equipment (WEEE) Statement

The product at end of life is subject to separate collection and treatment in the EU Member States, Norway and Switzerland and therefore marked with the symbol: .



Treatment applied at end of life of the product in these countries shall comply with the applicable national laws implementing directive 2002/96EC on waste electrical and electronic equipment (WEEE).

# China RoHS: Hazardous Substance Table

## 产品说明书附件

### SUPPLEMENT TO PRODUCT INSTRUCTIONS

这个文件涉及的是在中华人民共和国境内进口或销售的电子信息产品  
**Include this document with all Electronic Information Products imported or sold in the People's Republic of China**

部件名称 (Parts)	有毒有害物质或元素 (Hazardous Substance)					
	铅 (Pb)	汞 (Hg)	镉 (Cd)	六价铬 (Cr <sup>6+</sup> )	多溴联苯 (PBB)	多溴二苯醚 (PBDE)
电路模块 (Circuit Modules)	×	○	○	○	○	○
电缆及电缆组件 (Cables & Cable Assemblies)	×	○	○	○	○	○
金属部件 (Metal Parts)	×	○	○	○	○	○
塑料和聚合物部件 (Plastic and Polymeric parts)	○	○	○	○	○	○
对于交付时集成了电池的电子信息产品 For electronic information products delivered with integrated functional batteries:						
电池 (Batteries)	○	○	○	○	○	○
<p>○：表示该有毒有害物质在该部件所有均质材料中的含量均在 SJ/T11363-2006 标准规定的限量要求以下。 Indicates that the concentration of the hazardous substance in all homogeneous materials in the parts is below the relevant threshold of the SJ/T11363-2006 standard.</p> <p>×：表示该有毒有害物质至少在该部件的某一均质材料中的含量超出SJ/T11363-2006标准规定的限量要求。 Indicates that the concentration of the hazardous substance of at least one of all homogeneous materials in the parts is above the relevant threshold of the SJ/T11363-2006 standard.</p> <p>对销售之日的所售产品, 本表显示, 阿尔卡特朗讯公司供应链的电子信息产品可能包含这些物质。注意: 在所售产品中可能会也可能不会含有所有所列的部件。 <b>This table shows where these substances may be found in the supply chain of Alcatel-Lucent electronic information products, as of the date of sale of the enclosed product. Note that some of the component types listed above may or may not be a part of the enclosed product.</b></p>						

除非另外特别的标注, 此标志为针对所涉及产品的环保使用期标志。某些零部件会有一个不同的环保使用期(例如, 电池单元模块)贴在其产品上。  
 此环保使用期限只适用于产品是在产品手册中所规定的条件下工作。  
 The Environment-Friendly Use Period (EFUP) for all enclosed products and their parts are per the symbol shown here, unless otherwise marked. Certain parts may have a different EFUP (for example, battery modules) and so are marked to reflect such. The Environment-Friendly Use Period is valid only when the product is operated under the conditions defined in the product manual.



Products are packaged using one or more of the following packaging materials:

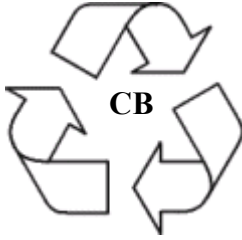

**Corrugated Cardboard**

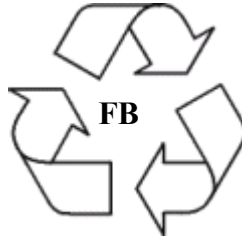

**Corrugated Fiberboard**



**Low-Density Polyethylene**

# Standards Compliance

The product bears the CE mark. In addition it is in compliance with the following other safety and EMC standards:

All hardware switching modules used in an OmniSwitch 9000 Series switch comply with Class A standards. Modules with copper connectors meet Class A requirements using unshielded (UTP) cables.

## Safety Standards

- UL 60950
- CAN/CSA-C22.2 No. 60950-00
- EN 60950-1:2001; all deviations
- IEC 60950-1:2001; all national deviations
- AS/NZS TS-001 and 60950: 2000, Australia
- UL-AR, Argentina
- TUV,UL-GS Mark, Germany
- NOM-019 SCFI, Mexico
- EN 60825-1 Laser
- EN 60825-2 Laser
- CDRH Laser
- CB Certification per IEC 950

## EMC Standards

- FCC Part 15 (CFR 47) Class A
- ICES-003 Class A
- EN 55022 Class A
- CISPR 22 Class A
- AS/NZS 3548 Class A
- VCCI Class A
- EN 55024: 1998 (Immunity)
- EN 50082-1
- EN 61000-3-2
- EN 61000-3-3
- EN 61000-4-2
- EN 61000-4-3
- EN 61000-4-4
- EN 61000-4-5
- EN 61000-4-6
- EN 61000-4-8
- EN 61000-6-2
- EN 61000-6-4
- EN 1000-4-11

## Environmental Standards

- ETS 300 019 Storage Class 1.1
- ETS 300 019 Transportation Class 2.3
- ETS 300 019 Stationary Use Class 3.1

## FCC Class A, Part 15

This equipment has been tested and found to comply with the limits for Class A digital device pursuant to Part 15 of the FCC Rules. These limits are designed to provide reasonable protection against harmful interference when the equipment is operated in a commercial environment. This equipment generates, uses, and can radiate radio frequency energy and, if not installed and used in accordance with the instructions in this guide, may cause interference to radio communications. Operation of this equipment in a residential area is likely to cause interference, in which case the user will be required to correct the interference at his own expense.

The user is cautioned that changes and modifications made to the equipment without approval of the manufacturer could void the user's authority to operate this equipment. It is suggested that the user use only shielded and grounded cables to ensure compliance with FCC Rules.

If this equipment does cause interference to radio or television reception, the user is encouraged to try to correct the interference by one or more of the following measures:

- Reorient the receiving antenna.
- Relocate the equipment with respect to the receiver.
- Move the equipment away from the receiver.
- Plug the equipment into a different outlet so that equipment and receiver are on different branch circuits.

If necessary, the user should consult the dealer or an experienced radio/television technician for additional suggestions.

## Canada Class A Statement

This equipment does not exceed Class A limits per radio noise emissions for digital apparatus, set out in the Radio Interference Regulation of the Canadian Department of Communications.

### **Avis de conformité aux normes du ministère des Communications du Canada**

Cet équipement ne dépasse pas les limites de Classe A d'émission de bruits radioélectriques pour les appareils numériques, telles que prescrites par le Règlement sur le brouillage radioélectrique établi par le ministère des Communications du Canada.

## JATE

This equipment meets the requirements of the Japan Approvals Institute of Telecommunications Equipment (JATE).

## CISPR22 Class A warning

This is a Class A product. In a domestic environment, this product may cause radio interference. Under such circumstances, the user may be requested to take appropriate countermeasures.

## VCCI

This is a Class A product based on the standard of the Voluntary Control Council for Interference by Information Technology Equipment (VCCI). If this equipment is used in a domestic environment, radio disturbance may arise. When such trouble occurs, the user may be required to take corrective actions.

この装置は、情報処理装置等電波障害自主規制協議会（VCCI）の基準に基づくクラスA情報技術装置です。この装置を家庭環境で使用すると電波妨害を引き起こすことがあります。この場合には使用者が適切な対策を講ずるよう要求されることがあります。

## Class A Warning for Taiwan and Other Chinese Markets

This is a Class A Information Product. When used in a residential environment, it may cause radio frequency interference. Under such circumstances, the user may be requested to take appropriate countermeasure.

**警告使用者：**  
這是甲類的資訊產品，在居住的環境中使用時，可能會造成射頻干擾，在這種情況下，使用者會被要求採取某些適當的對策。



# Translated Safety Warnings

## Chassis Lifting Warning

Two people are required when lifting the chassis. Due to its weight, lifting the chassis unassisted can cause personal injury. Also be sure to bend your knees and keep your back straight when assisting with the lifting of the chassis.

**Français:** Le châssis doit être soulevé par deux personnes au minimum. Pour éviter tout risque d'accident, maintenez le dos droit et poussez sur vos jambes. Ne soulevez pas l'unité avec votre dos.

**Deutsch: Sicherheitshinweise**

Hinweise zur Anhebung des Chassis

Zum Anheben des Chassis werden zwei Personen benötigt. Aufgrund des Gewichts kann das Anheben ohne Unterstützung zu Personenschäden führen. Heben Sie das Chassis aus den Knien und halten Sie den Rücken gerade wenn Sie beim Anheben des Chassis assistieren.

**Español:** Se requieren dos personas para elevar el chasis. Para evitar lesiones, mantenga su espalda en posición recta y levante con sus piernas, no con su espalda.

## Blank Panels Warning

Because they regulate airflow and help protect internal chassis components, blank cover plates should remain installed at empty module slots and power supply bays at all times.

**Français:** Les caches blancs remplissent trois fonctions importantes : ils évitent tout risque de choc électrique à l'intérieur du châssis, ils font barrage aux interférences électromagnétiques susceptibles d'altérer le fonctionnement des autres équipements et ils dirigent le flux d'air de refroidissement dans le châssis. Il est vivement recommandé de vérifier que tous les caches, modules d'alimentation et plaques de protection sont en place avant d'utiliser le système.

**Deutsch:** Hinweise zu Abdeckungen

Die leeren Modulblenden schützen interne Komponenten und leiten den Luftstrom. Deshalb müssen in allen unbelegten Slots die Modulblenden immer installiert bleiben.

**Español:** Las tapaderas blancas regulan la circulación de aire y ayudan a proteger componentes internos del chasis y siempre deben estar instaladas en las ranuras vacías del chasis y fuentes de alimentación.

## Electrical Storm Warning

To avoid a shock hazard, do not connect or disconnect any cables or perform installation, maintenance, or reconfiguration of this product during an electrical storm.

**Français:** Ne pas travailler sur le système ni brancher ou débrancher les câbles pendant un orage.

**Deutsch:** Hinweise bei Unwetter

Um elektrische Schläge zu vermeiden dürfen während eines Gewitters and diesem Gerät keine Kabel angeschlossen oder gelöst werden, sowie keinerlei Installationen, Wartungen oder Konfigurationen vorgenommen werden.

**Español:** Para evitar peligro de descargas, no conecte o desconecte ningún cable, ni realice ninguna instalación, mantenimiento o reconfiguración de este producto durante una tormenta eléctrica.

## Installation Warning

Only personnel knowledgeable in basic electrical and mechanical procedures should install or maintain this equipment.

**Français:** Toute installation ou remplacement de l'appareil doit être réalisée par du personnel qualifié et compétent.

**Deutsch:** Installationshinweise

Dieses Gerät soll nur von Personal installiert oder gewartet werden, welches in elektrischen und mechanischen Grundlagen ausgebildet ist.

**Español:** Estos equipos deben ser instalados y atendidos exclusivamente por personal adecuadamente formado y capacitado en técnicas eléctricas y mecánicas.

## Invisible Laser Radiation Warning

Lasers emit invisible radiation from the aperture opening when no fiber-optic cable is connected. When removing cables do not stare into the open apertures. In addition, install protective aperture covers to fiber ports with no cable connected.

**Français:** Des radiations invisibles à l'œil nu pouvant traverser l'ouverture du port lorsque aucun câble en fibre optique n'y est connecté, il est recommandé de ne pas regarder fixement l'intérieur de ces ouvertures. Installez les caches connecteurs prévus à cet effet.

**Deutsch:** Hinweise zur unsichtbaren Laserstrahlung

Die Laser strahlen an der Blendenöffnung unsichtbares Licht ab, wenn keine Glasfaserkabel angeschlossen sind. Blicken Sie nicht in die Öffnungen und installieren Sie unverzüglich die Abdeckungen über den Glasfaseranschlüssen.

**Español:** Debido a que la apertura del puerto puede emitir radiación invisible cuando no hay un cable de fibra conectado, procurar no mirar directamente a las aperturas para no exponerse a la radiación.

## Lithium Battery Warning

There is a danger of explosion if the Lithium battery in your chassis is incorrectly replaced. Replace the battery only with the same or equivalent type of battery recommended by the manufacturer. Dispose of used batteries according to the manufacturer's instructions. The manufacturer's instructions are as follows: Return the module with the Lithium battery to Alcatel-Lucent. The Lithium battery will be replaced at Alcatel-Lucent's factory.

**Français:** Il y a un danger d'explosion si la batterie de lithium dans votre châssis est remplacée avec une autre ne correspondant pas aux préconisations constructeur. Il faut donc renvoyer le module en réparation chez Alcatel-Lucent qui se chargera de remplacer la batterie.

**Deutsch:** Hinweise zur Lithium Batterie

Bei falschem Einsetzen der Lithiumbatterie in das Gerät besteht die Gefahr der Explosion. Bitte ersetzen Sie die Batterie nur durch den gleichen bzw. gleichwertigen Typ, empfohlen durch den Hersteller. Benutzte Batterien entsorgen sie bitte wie folgt: Bitte senden Sie das Modul zurück zu Alcatel-Lucent. Dort wird die gebrauchte Batterie ersetzt.

**Español:** Si substituye las pilas de litio en su chasis, siempre utilice el mismo modelo o el tipo equivalente de pila recomendada por el fabricante. Deshágase de las pilas usadas según las instrucciones del fabricante. Devuelva el módulo con la pila de litio a Alcatel-Lucent. La pila de litio será substituida en la fábrica de Alcatel-Lucent.

**Dansk:** ADVARSEL! Lithiumbatteri--Eksplosionsfare ved fejlagtig handling. Udskiftning ma kun ske batteri af samme fabrikat og type. Lever det brugte batteri tilbage tilleverandoren.

## Operating Voltage Warning

To reduce the risk of electrical shock, keep your hands and fingers out of power supply bays and do not touch the backplane while the switch is operating.

**Français:** Pour réduire tout risque électrique, gardez vos mains et doigts hors des alimentations et ne touchez pas au fond de panier pendant que le commutateur fonctionne.

**Deutsch:** Hinweise gegen elektrischen Schlag

Um die Gefahr des elektrischen Schlages zu verringern, greifen sie bitte nicht in die Spannungsversorgung und berühren sie nicht die Rückwandplatine während das Gerät arbeitet.

**Español:** Para reducir el riesgo de descargas eléctricas, no meta sus manos y dedos dentro del chasis de la fuente de alimentación y no toque componentes internos mientras que el interruptor está conectado.

## Power Disconnection Warning

Your switch is equipped with multiple power supplies. To reduce the risk of electrical shock, be sure to disconnect all power connections before servicing or moving the unit.

**Français:** Il se peut que cette unité soit équipée de plusieurs raccordements d'alimentation. Pour supprimer tout courant électrique de l'unité, tous les cordons d'alimentation doivent être débranchés.

**Deutsch:** Hinweise zur Spannungsfreischaltung

Ihr Gerät ist mit mehreren Netzteilen ausgerüstet. Um die Gefahr des elektrischen Schlages zu verringern, stellen sie sicher, daß alle Netzverbindungen getrennt sind bevor das Gerät gewartet oder bewegt wird.

**Español:** Antes de empezar a trabajar con un sistema, asegúrese que el interruptor está cerrado y el cable eléctrico desconectado.

## Proper Earthing Requirement Warning

To avoid shock hazard:

- The power cord must be connected to a properly wired and earth receptacle.
- Any equipment to which this product will attached must also be connected to properly wired receptacles.

**Français:**

Pour éviter tout risque de choc électrique:

- Ne jamais rendre inopérant le conducteur de masse ni utiliser l'équipement sans un conducteur de masse adéquatement installé.
- En cas de doute sur la mise à la masse appropriée disponible, s'adresser à l'organisme responsable de la sécurité électrique ou à un électricien.

**Deutsch:** Hinweise zur geforderten Erdung des Gerätes

Aus Sicherheitsgründen:

- darf das Netzkabel nur an eine Schutzkontaktsteckdose angeschlossen werden.
- dürfen für den Anschluß anderer Geräte, welche mit diesem Gerät verbunden sind, auch nur Schutzkontaktsteckdosen verwendet werden.

**Español:**

Para evitar peligro de descargas:

- Para evitar peligro de descargas asegúrese de que el cable de alimentación está conectado a una toma de alimentación adecuadamente cableada y con toma de tierra.
- Cualquier otro equipo a cual se conecte este producto también debe estar conectado a tomas de alimentación adecuadamente cableadas.

## Read Important Safety Information Warning

The *Getting Started Guide* that accompanied this equipment contains important safety information about which you should be aware when working with hardware components in this system. You should read this guide before installing, using, or servicing this equipment.

**Français:** Avant de brancher le système sur la source d'alimentation, consultez les directives d'installation disponibles dans le "Getting Started Guide".

**Deutsch:** Bitte lesen - Sicherheitshinweise

Der Getting Started Guide, welcher diese Anlage beiliegt, enthält wichtige Sicherheitsinformationen, über die sie sich beim Arbeiten mit den Hardwareeinheiten bewußt sein sollten. Sie sollten diese Hinweise lesen, bevor sie installieren, reparieren oder die Anlage verwenden.

**Español:** La 'Getting Started Guide' que acompañó este equipo contiene información importante de seguridad sobre la cual usted debe estar enterado al trabajar con los componentes de dotación física en este sistema. Usted debe leer esta guía antes de instalar, usar o mantener este equipo.

## Restricted Access Location Warning

This equipment should be installed in a location that restricts access. A restricted access location is one where access is secure and limited to service personnel who have a special key, or other means of security.

**Français:** Le matériel doit être installé dans un local avec accès limité ou seules les personnes habilitées peuvent entrer.

**Deutsch:** Hinweis zu Umgebungen mit beschränktem Zutritt

Die Anlage sollte an einem Standort mit beschränktem Zutritt installiert sein. Ein Standort mit beschränktem Zutritt stellt sicher, daß dort nur Servicepersonal mit Hilfe eines Schlüssels oder eines anderen Sicherheitssystems Zugang hat.

**Español:** Este equipo se debe instalar en un sitio con acceso restringido. Un sitio con el acceso restringido es uno seguro y con acceso limitado al personal de servicio que tiene una clave especial u otros medios de seguridad.

## Wrist Strap Warning

Because electrostatic discharge (ESD) can damage switch components, you must ground yourself properly before continuing with the hardware installation. For this purpose, Alcatel-Lucent provides a grounding wrist strap and a grounding lug located near the top-right of the chassis. For the grounding wrist strap to be effective in eliminating ESD, the power supplies must be installed in the chassis and plugged into grounded AC outlets.

**Français:** L'électricité statique (ESD) peut endommager les composants du commutateur. Pour cette raison Alcatel-Lucent joint à l'envoi du châssis un bracelet antistatique à brancher sur la prise mise à la terre située en bas à droite du commutateur. Vous devrez mettre ce bracelet avant toute intervention hardware.

**Deutsch:** Hinweise zur ESD (Elektrostatischen Aufladung)

Weil elektrostatische Aufladung (ESD) Teile der Anlage beschädigen könnten, müssen sie sich selbst erden, bevor sie mit der Hardware Installation beginnen. Zu diesem Zweck stellt Alcatel-Lucent ein Erdungsarmband und eine Erdungsöse an der oberen rechten Seite des Chassis zur Verfügung. Um eine sichere Erdungsfunktion des Erdungsarmbandes sicherzustellen, müssen die Netzteile installiert und mit dem Schutzleiter des Versorgungsstromkreises verbunden sein.

**Español:** La descarga electrostática (ESD) puede dañar componentes electrónicos. Usted debe asegurarse que está en contacto con tierra antes de hacer la instalación del equipo. Con este fin, Alcatel-Lucent proporciona una pulsera de muñeca para conectar al chasis en la toma de tierra situada en la parte superior derecha del chasis. Para que la correa de muñeca sea eficaz en la eliminación de ESD, las fuentes de alimentación deben estar instaladas en el chasis y conectadas a enchufes CA con tierra adecuada.

# Instrucciones de seguridad en español

## Advertencia sobre el levantamiento del chasis

Se requieren dos personas para levantar el chasis. Debido a su peso, la elevación del chasis sin ayuda puede causar daños corporales. También es seguro doblar sus rodillas y guardar su espalda derecho al ayudar a levantar el chasis.

## Advertencia de las tapaderas en blanco

Porque regulan la circulación de aire y ayudan a proteger componentes internos del chasis, las tapaderas en blanco deben seguir instaladas en las ranuras vacías del módulo y la fuente de alimentación siempre.

## Advertencia en caso de tormenta eléctrica

Para evitar peligro de descargas, no conecte o desconecte ningún cable, ni realice ninguna instalación, mantenimiento o reconfiguración de este producto durante una tormenta eléctrica.

## Advertencia de instalación

Solamente el personal bien informado en procedimientos eléctricos y mecánicos básicos debe instalar o mantener este equipo.

## Advertencia de radiación láser invisible

Los lasers emiten radiación invisible de la apertura abierta cuando no se conecta ningún cable de fibra óptica. Al quitar los cables no mire fijamente en las aberturas abiertas. Además, instale las cubiertas protectoras de la apertura a las salidas de la fibra sin el cable conectado.

## Advertencia de la batería de litio

Hay un peligro de la explosión si la batería del litio en su chasis se substituye incorrectamente. Substituya la batería solamente por el mismo o el equivalente de tipo de batería recomendado por el fabricante. Deseche las baterías usadas según las instrucciones del fabricante. Las instrucciones del fabricante son como sigue: Devuelva el módulo con la batería del litio a Alcatel-Lucent. La batería del litio será substituida en la fábrica de Alcatel-Lucent.

## Advertencia sobre la tensión de operación

Para reducir el riesgo del choque eléctrico, mantenga sus manos y dedos fuera de la fuente de alimentación y no toque la placa madre mientras que el interruptor está funcionando.

## Advertencia sobre la desconexión de la fuente

Su interruptor esta equipado por fuentes de alimentación múltiples. Para reducir el riesgo de choque eléctrico, asegúrese desconectar todas las conexiones de alimentación antes de mantener o de mover la unidad.

## **Advertencia sobre una apropiada conexión a tierra**

Para evitar peligro de descargas:

- El cable de alimentación debe estar conectado a una toma de alimentación adecuadamente cableada y con toma de tierra.

Cualquier equipo al cual se conecte este producto debe estar también conectado a tomas de alimentación adecuadamente cableadas.

## **Leer “información importante de seguridad”**

La *Guía de “Comenzando a Usar”* que acompaña este equipo contiene información importante de seguridad sobre la cual usted debe saber al trabajar con los componentes de dotación física en este sistema. Usted debe leer esta guía antes de instalar, de usar, o de mantener este equipo.

## **Advertencia de acceso restringido**

Este equipo se debe instalar en una ubicación que restrinja el acceso. Una ubicación con acceso restringido es una donde está seguro y limitado el acceso al personal de servicio que tiene un clave especial, u otros medios de la seguridad.

## **Advertencia de pulsera antiestática**

Debido a que la descarga electrostática (ESD) puede dañar componentes del interruptor, usted debe conectarse a tierra correctamente antes de continuar con la instalación del equipo. Para este propósito, Alcatel-Lucent proporciona una pulsera antiestática y un terminal que pone a tierra situados cerca de la parte superior derecha del chasis. Para que la pulsera antiestática sea eficaz en la eliminación de ESD, las fuentes de alimentación se deben instalar en el chasis y enchufar en las salidas de CA con descarga a tierra.

## **Clase de seguridad**

Cumple con 21CFR 1040.10 y 1040.11 ó sus equivalentes.

## **Advertencia de fuentes de poder**

Las unidades OmniSwitch 9700 pueden estar equipadas con tres cordones para fuente de poder. Para reducir el riesgo de un choque eléctrico, desconecte todos los cordones de fuente de poder antes de dar servicio a la unidad.



# Index

## A

- airflow
  - chassis 2-36
  - power supply 2-38
- availability 1-2
  - hardware monitoring 1-4
  - hardware redundancy 1-2
  - hot swapping 1-4
  - power checking 1-5
  - Smart Continuous Switching 1-3
  - software rollback 1-3

## B

- blank cover panels
  - airflow 2-39

## C

- chassis
  - airflow 2-9, 2-36
  - blank cover panels 2-39
  - fan tray 2-32
  - MAC address 3-18
  - personal grounding lug 4-14
  - rack-mounting 2-10
  - slot numbering 2-8
  - standalone 2-10
  - supplemental ground 2-30
  - temperature management 2-30
- Chassis Management Module
  - see* CMM
- chassis temperature
  - monitoring 2-30
- chassis types 1-1, 2-2, 2-5
  - OS9700 (10-slot) 1-1
  - OS9700 (8-slot) 2-5
  - OS9800 (16-slot) 2-2
- CLI commands
  - supported on secondary CMM 3-16
- CMM 3-1
  - commands supported on secondary 3-16
  - console port 3-3, 3-7
  - Ethernet Management Port 3-3, 3-5
  - failover 3-10
  - front panel 3-3
  - hot swapping 3-12
  - LEDs 3-3
  - managing 3-14
  - monitoring 3-15
  - OS7700-CMM 3-2

- OS7800-CMM 3-2
  - primary 3-10
  - redundancy 3-10
  - reloading 3-14
  - secondary 3-10
  - slot locations 3-2
  - switching fabric 3-11
  - switching the primary and secondary roles 3-14
  - synchronizing primary and secondary 3-11
  - technical specifications 2-32, 3-5
  - USB port 3-3
- console port 3-7
  - default settings 3-7
  - modifying 3-5, 3-7, 3-9
- copy flash-synchro** command 3-11

## E

- Ethernet Management Port (EMP) 3-5

## F

- fan tray 2-32
  - fan redundancy 2-33
  - hot swapping 2-33
  - installing 2-35
  - monitoring 2-33
  - removing 2-34
  - technical specifications 2-32
- fans
  - chassis 2-32
  - power supplies 2-38
  - redundancy 2-33
- fiber
  - handling 4-20

## G

- GNI modules
  - features 4-3
    - OS9-GNI-C24 4-3, 4-4
    - OS9-GNI-U24 4-3, 4-6
- grounding lug 4-14

## H

- hardware monitoring 1-4
  - automatic 1-4
  - LEDs 1-4, 3-3, 4-4, 4-6, 4-9
  - user-driven 1-4
- hot swapping 1-4
  - CMMs 1-4
  - fan tray 1-4
  - NI modules 1-4
  - power supplies 1-4

## I

- image rollback
  - see* software rollback

**J**

jumbo frames 4-5, 4-7

**L**

LEDs

*see* hardware monitoring

**N**

Network Interface Modules

*see* NI modules

NI modules

boot sequence 1-5, 4-11

handling fiber 4-20

hot swapping 4-13

installing 4-15

locations 4-15

managing 4-11

monitoring 4-12

OS9-GNI-C24 4-4

OS9-GNI-U24 4-6

OS9-XNI-U2 4-9

pinouts 3-18, 4-15, 4-19

power checking 1-5

powering on or off 4-11

reloading 4-11

removing and adding 4-14

technical specifications 4-5, 4-7, 4-10

**no power ni** command 4-11

**O**

OmniSwitch 9700 2-5

technical specifications 2-7

OmniSwitch 9700 series 1-1

OmniSwitch 9800 2-2

technical specifications 2-4

OS7700-CMM 3-2

OS7800-CMM 3-2

OS9700 (10-slot)

*see* OmniSwitch 9700

OS9700 (8-slot)

*see* OmniSwitch 9700

OS9800 (16-slot)

*see* OmniSwitch 9800

OS9-GNI-C24 4-4

front panel 4-4

LEDs 4-4

ports 4-4

technical specifications 4-5

OS9-GNI-U24 4-6

front panel 4-6

LEDs 4-6

ports 4-6

technical specifications 4-7

OS9-XNI-U2 4-9

front panel 4-9

LEDs 4-9

ports 4-9

technical specifications 4-10

**P**

power checking

*see* NI modules

power cords 2-28

**power ni** command 4-11

power supplies 2-13, 2-15

airflow 2-38

fans 2-38

installing 2-25

power cords 2-28

redundancy 2-13, 2-15

redundant AC circuits 2-29

removing 2-27

technical specifications 2-14, 2-16

**R**

redundancy 1-2

AC circuit 2-29

CMM 3-10

commands supported on secondary CMM 3-16

fans 2-33

hardware 1-2

MAC EEPROM 3-18

power supplies 2-13, 2-15

**reload** command 3-14

**reload ni** command 4-11

**S**

**session xon-xoff** command 3-9

**show cmm** command 3-15

**show fan** command 2-31, 2-33, 3-16

**show hardware info** command 3-16

**show module** command 2-9

**show module long** command 2-9

**show ni** command 4-12

**show running-directory** command 3-14

**show temperature** command 2-30, 2-31, 3-16

slot numbering 2-8

Smart Continuous Switching 1-3, 4-11

software rollback 1-3

**T**

**takeover** command 3-14

technical specifications

CMM 2-32, 3-5

fans 2-32

NI modules 4-5, 4-7, 4-10

OmniSwitch 9700 2-7

OmniSwitch 9800 2-4

power supplies 2-14, 2-16

temperature management 2-30

danger threshold 2-31

errors 2-31

warning threshold 2-31

**temp-threshold** command 2-31

## **X**

XNI modules

features 4-8

OS9-XNI-U2 4-8, 4-9

